

FAG

State-of-the-Art Protection for Your Bearings

Introducing the Next-Generation SAF Housings from Schaeffler

Completely redesigned and reengineered, Schaeffler's new generation of SAF housings feature numerous improvements that ensure optimal bearing performance in a broad range of applications. Designed to meet the industry standard for SAF 500 series pillow block housings, they combine exceptional load carrying capacity with reliable performance and unsurpassed versatility. Schaeffler's all-new lineup of SAF housings can accept a full range of shaft diameters from 1 $\frac{3}{8}$ inches to 8 inches. Only from Schaeffler.

SCHAEFFLER

At a glance: 9 essential advantages of Schaeffler's new and improved SAF bearing housings

Versatile and incredibly capable: Designed for FAG spherical roller bearings series 222..-K and FAG split spherical roller bearings series 222S, which offer even less downtime and unmatched ease of installation.

Designed around your needs: Available in either gray cast iron or ductile cast iron, SAF housings enable you to tailor your bearing housing solution to your application and budget.

The complete package: For maximum flexibility, both material types are delivered standard as a universal housing design that comes complete with a full set of accessories:

- Two standard triple-seal rings with O-ring for the applicable shaft size; other seal ring sizes available upon request
- Stabilizing ring for locating assembly
- End cover
- Grease fittings

Superior protection against contamination: In addition to the included standard triple-seal ring, also known as a non-contact radial labyrinth – or LER – seal, Schaeffler's new SAF housing can also be equipped with SuperTac II taconite seals for severe operating conditions.

Optimal lubrication under all conditions: Two lubricating holes ② that guide grease to either the outer ring or the side of the bearing as well as precisely machined discharge holes ⑥ on each side of the block prevent lubricant starvation – regardless of the housing's orientation.

Suitable for oil lubrication: Features include labyrinth seals with O-ring as well as oil sump equalizer holes ⑤ in the housing's base.

Precise mounting assured: Markings clearly identify the center of the housing ③, while machined locating faces ④ enable quick and accurate positioning.

Industry-leading expandability: Each housing includes multiple predefined connecting points ① for attaching condition monitoring sensors such as Schaeffler's palm-sized FAG SmartCheck as well as lubrication systems.

Bottom line – less downtime: Sophisticated computer-aided design improvements significantly increase the housing's strength. You benefit from a more robust housing that delivers exceptional load carrying capacity.

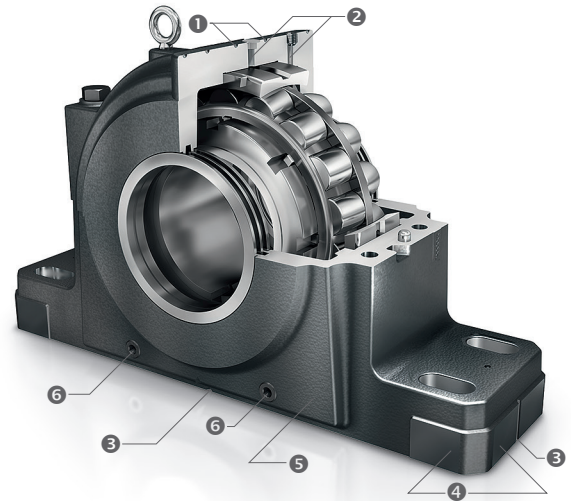

For a comprehensive technical overview of Schaeffler's SAF split pillow block housings, please refer to our technical publication TPI 229.

