

# SPHERICAL PLAIN BEARINGS



# TABLE OF CONTENTS

**S**pherical Plain Bearings utilize inner & outer rings with spherical sliding surfaces, and can accommodate heavy radial loads & bi-directional axial loads at the same time. They are produced in a wide variety of designs & materials to satisfy diverse demands such as those in the automation, construction, mining, transportation, off-highway equipment, farming & machine tool applications.

Standard designs utilize carbon chromium steel on steel which is hardened, phosphated and treated with Molybdenum Disulfide (MoS<sub>2</sub>) to reduce friction. Most designs can be relubricated through annular grooves & lubrication holes in the outer rings.

Bearings are also available in self lubricating designs utilizing PTFE lined races offering a maintenance free solution with lower friction. For corrosive environments, many sizes can be supplied in stainless steel construction.

<i>Type</i>	<i>Page</i>
<b>Radial Inch</b>	
GEZ...E/ES, General Purpose	1
COM, Commercial	2
<b>Radial Metric</b>	
GE...E/ES, General Purpose	3
GEH...E/ES, Heavy	4
GE...C, Maintenance Free	5
GEH...C, Heavy - Maintenance Free	5
GEG...ES, Extended Inner Ring	6
GEM...ES, Extended Inner Ring	7
<b>Angular Contact</b>	
GAZ...SA, Inch	8
GAC...T, Metric - Maintenance Free	9
<b>Thrust</b>	
GX...T, Metric - Maintenance Free	10

The above are typically available from stock. Other configurations of Spherical Plain Bearings are available from the factory subject to normal lead times. Minimum orders may apply. Contact your distributor for additional information.

# SPHERICAL PLAIN BEARINGS – INCH

## GEZ SERIES

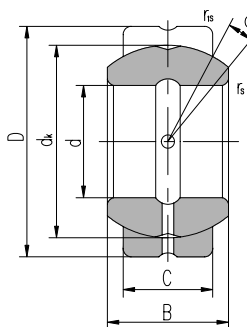

GEZ...ES

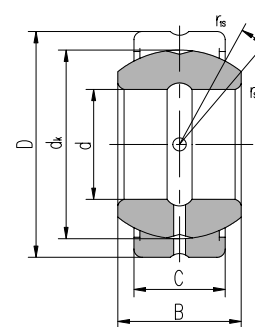

GEZ...ES-2RS

### Specifications

- Sliding Surface: Steel on Steel - MoS<sub>2</sub> treated
- Single Fracture Design
- Relubricatable through annular grooves & oil holes in inner & outer rings (ES – Suffix)

Part #	Ref #	Dimensions (inches)								Load Ratings kN		Weight LBS
		d	D	B	C	d	r <sub>s</sub> min	r <sub>is</sub> min	α ≈	Dynamic	Static	
GEZ 008ES	GEZ12ES	0.5	0.875	0.437	0.375	0.707	0.006	0.024	6	13	41	.048
GEZ 010ES	GEZ15ES	0.625	1.0625	0.547	0.469	0.904	0.006	0.024	6	22	65	.079
GEZ 012ES	GEZ19ES	0.75	1.25	0.656	0.562	1.081	0.012	0.024	6	31	95	.12
GEZ 014ES	GEZ22ES	0.875	1.4375	0.756	0.656	1.258	0.012	0.024	6	42	127	.19
GEZ 100ES	GEZ25ES	1	1.625	0.875	0.75	1.437	0.012	0.024	6	56	166	.27
GEZ 104ES	GEZ31ES	1.25	2	1.093	0.937	1.788	0.024	0.024	6	86	260	.51
GEZ 106ES	GEZ34ES	1.375	2.1875	1.187	1.031	1.926	0.024	0.04	6	102	310	.77
GEZ 108ES	GEZ38ES	1.5	2.4375	1.312	1.125	2.154	0.024	0.04	6	125	375	.92
GEZ 112ES	GEZ44ES	1.75	2.8125	1.531	1.312	2.511	0.024	0.04	6	170	510	1.41
GEZ 200ES	GEZ50ES	2	3.1875	1.75	1.5	2.869	0.024	0.04	6	224	670	2.05
GEZ 204ES	GEZ57ES	2.25	3.5625	1.969	1.687	3.223	0.024	0.04	6	280	850	2.90
GEZ 208ES	GEZ63ES	2.5	3.9375	2.187	1.875	3.616	0.04	0.04	6	355	1060	4.07
GEZ 212ES	GEZ69ES	2.75	4.375	2.406	2.062	3.937	0.04	0.04	6	415	1250	5.28
GEZ 300ES	GEZ76ES	3	4.75	2.625	2.25	4.303	0.04	0.04	6	500	1500	6.82
GEZ 304ES	GEZ82ES	3.25	5.125	2.844	2.437	4.685	0.04	0.04	6	585	1760	8.36
GEZ 308ES	GEZ88ES	3.5	5.5	3.062	2.625	5.04	0.04	0.04	6	680	2040	10.60
GEZ 312ES	GEZ95ES	3.75	5.875	3.281	2.812	5.393	0.04	0.04	6	780	2360	12.76
GEZ 400ES	GEZ101ES	4	6.25	3.5	3	5.748	0.04	0.04	6	900	2650	15.40
GEZ 404ES	GEZ107ES	4.25	6.625	3.719	3.187	6.102	0.04	0.04	6	1000	3000	18.50
GEZ 408ES	GEZ114ES	4.5	7	3.937	3.375	6.476	0.04	0.04	6	1120	3400	21.60
GEZ 412ES	GEZ120ES	4.75	7.375	4.156	3.562	6.83	0.04	0.04	6	1250	3750	25.30
GEZ 500ES	GEZ127ES	5	7.75	4.375	3.75	7.204	0.04	0.04	6	1400	4150	29.70
GEZ 600ES	GEZ152ES	6	8.75	4.75	4.125	8.15	0.04	0.04	5	1730	5200	38.50

Also available: Maintenance Free – PTFE Lined – GEZ...TE 2RS, Stainless Steel – GEZ...TE/X

Common Interchanges (1" Bore): 10SF16, B16L, GE25ZO, SA2-16B, SBB16



# SPHERICAL PLAIN BEARINGS – INCH

## COM SERIES

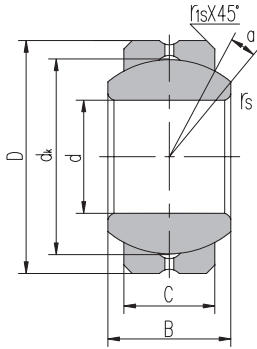

### Specifications

- Sliding Surface: Steel on Steel – Chrome Plated Ball
- Relubricatable through annular grooves & oil holes in inner ring

Part #	Ref #	Dimensions (inches)								Load Ratings kN		Weight LBS
		d	D	B	C	d <sub>k</sub>	r <sub>s</sub> min	r <sub>1s</sub> min	α ≈	Dynamic	Static	
COM 3	GEFZ4S	0.19	0.5625	0.281	0.218	0.406	0.012	0.015	11	3	15	.013
COM 4	GEFZ6S	0.25	0.6562	0.343	0.25	0.5	0.012	0.022	13.5	4.4	22	.022
COM 5	GEFZ7S	0.3125	0.75	0.375	0.281	0.562	0.012	0.032	12	6	28	.031
COM 6	GEFZ9S	0.375	0.8125	0.406	0.312	0.656	0.012	0.032	10	7.4	37	.037
COM 7	GEFZ11S	0.4375	0.9062	0.437	0.343	0.687	0.012	0.032	8	8.4	42	.046
COM 8	GEFZ12S	0.5	1	0.5	0.39	0.813	0.012	0.032	9.5	12	58	.064
COM 9	GEFZ14S	0.5625	1.0937	0.562	0.437	0.906	0.012	0.032	9.5	15	73	.086
COM 10	GEFZ15S	0.625	1.1875	0.625	0.5	1	0.012	0.032	9.5	19	94	.110
COM 12	GEFZ19S	0.75	1.4375	0.75	0.593	1.187	0.012	0.044	9	28	141	.200
COM 14	GEFZ22S	0.875	1.5625	0.703	0.875	1.312	0.024	0.044	9.5	37	186	.261
COM 16	GEFZ25S	1	1.75	1	0.797	1.5	0.024	0.044	10	49	245	.385

Also available: Maintenance Free – PTFE Lined – COM...T, Stainless Steel – SSCOM

Common Interchanges (1/2" Bore): CRS 8



# SPHERICAL PLAIN BEARINGS – METRIC

## GE SERIES

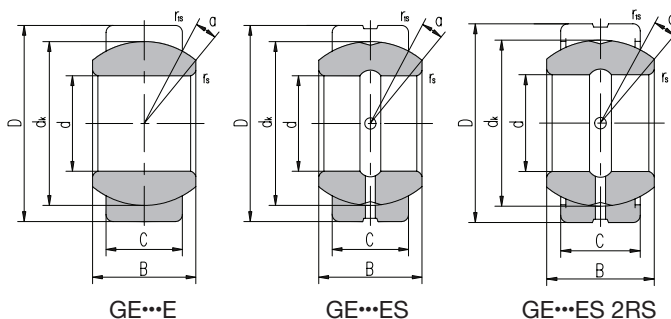

### Specifications

- Sliding Surface: Steel on Steel - MoS<sub>2</sub> treated
- Single Fracture Design
- Relubricatable through annular grooves & oil holes in inner & outer rings (ES – Suffix)

Part #	Dimensions (mm)								Load Ratings kN		Weight LBS
	d	D	B	C	d <sub>k</sub>	r <sub>s</sub> min	r <sub>is</sub> min	α ≈	Dynamic	Static	
GE4E	4	12	5	3	8	0.3	0.3	16	2	10	.007
GE5E	5	14	6	4	10	0.3	0.3	13	3.4	17	.008
GE6E	6	14	6	4	10	0.3	0.3	13	3.4	17	.009
GE8E	8	16	8	5	13	0.3	0.3	15	5.5	27	.018
GE10E	10	19	9	6	16	0.3	0.3	12	8.1	40	.024
GE12E	12	22	10	7	18	0.3	0.3	10	10	53	.033
GE15ES	15	26	12	9	22	0.3	0.3	8	16	84	.059
GE17ES	17	30	14	10	25	0.3	0.3	10	21	106	.090
GE20ES	20	35	16	12	29	0.3	0.3	9	30	146	.262
GE25ES	25	42	20	16	35.5	0.6	0.6	7	48	240	.262
GE30ES	30	47	22	18	40.7	0.6	0.6	6	62	310	.337
GE35ES	35	55	25	20	47	0.6	1	6	79	399	.513
GE40ES	40	62	28	22	53	0.6	1	7	99	495	.673
GE45ES	45	68	32	25	60	0.6	1	7	127	637	.939
GE50ES	50	75	35	28	66	0.6	1	6	156	780	1.20
GE55ES	55	85	40	32	74	0.6	1	7	200	1000	2.07
GE60ES	60	90	44	36	80	1	1	6	245	1220	2.29
GE70ES	70	105	49	40	92	1	1	6	313	1560	3.41
GE80ES	80	120	55	45	105	1	1	6	400	2000	5.08
GE90ES	90	130	60	50	115	1	1	5	488	2440	6.05
GE100ES	100	150	70	55	130	1	1	7	607	3030	9.79
GE110ES	110	160	70	55	140	1	1	6	654	3270	10.60
GE120ES	120	180	85	70	160	1	1	6	950	4750	17.71
GE140ES	140	210	90	70	180	1	1	7	1070	5350	24.24
GE160ES	160	230	105	80	200	1	1	8	1360	6800	30.82
GE180ES	180	260	105	80	225	1.1	1.1	6	1530	7650	41.00
GE200ES	200	290	130	100	250	1.1	1.1	7	2120	10600	62.00
GE220ES	220	320	135	100	275	1.1	1.1	8	2320	11600	78.00
GE240ES	240	340	140	100	300	1.1	1.1	8	2550	12700	88.00
GE260ES	260	370	150	110	325	1.1	1.1	7	3030	15190	113.00
GE280ES	280	400	155	120	350	1.1	1.1	6	3570	17850	143.00
GE300ES	300	430	165	120	375	1.1	1.1	7	3800	19100	172.00

Also available: Maintenance Free – PTFE Lined – GE...TE 2RS, Stainless Steel – GE...TE/X

Common Interchanges (100mm Bore): GE2100DO, 100SF150, MB100, SA1-100B, SBH100S



www.bl-bearings.com

# SPHERICAL PLAIN BEARINGS – METRIC

## GEH SERIES

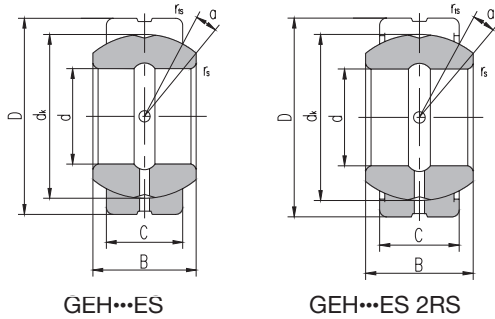

### Specifications

- Wider Inner Ring & larger OD – Capable of greater misalignment
- Sliding Surface: Steel on Steel - MoS<sub>2</sub> treated

- Single Fracture Design
- Relubricatable through annular grooves & oil holes in inner & outer rings (ES – Suffix)

Part #	Ref #	Dimensions (mm)								Load Ratings kN		Weight LBS
		d	D	B	C	d <sub>k</sub>	r <sub>s</sub> min	r <sub>is</sub> min	α ≈	Dynamic	Static	
GEH4E	GEG4E	4	14	7	4	10	0.3	0.3	20	3.4	17	.011
GEH5E	GEG5E	5	16	9	5	13	0.3	0.3	21	5.5	27	.018
GEH6E	GEG6E	6	16	9	5	13	0.3	0.3	21	5.5	27	.025
GEH8E	GEG8E	8	19	11	6	16	0.3	0.3	21	8.1	40	.030
GEH10E	GEG10E	10	22	12	7	18	0.3	0.3	18	10	53	.046
GEH12E	GEG12E	12	26	15	9	22	0.3	0.3	18	16	84	.073
GEH15ES	GEG15ES	15	30	16	10	25	0.3	0.3	16	21	106	.108
GEH17ES	GEG17ES	17	35	20	12	29	0.3	0.3	19	30	146	.183
GEH20ES	GEG20ES	20	42	25	16	35.5	0.3	0.6	17	48	240	.337
GEH25ES	GEG25ES	25	47	28	18	40.7	0.6	0.6	17	62	310	.450
GEH30ES	GEG30ES	30	55	32	20	47	0.6	1	17	79	399	.670
GEH35ES	GEG35ES	35	62	35	22	53	0.6	1	16	99	495	.900
GEH40ES	GEG40ES	40	68	40	25	60	0.6	1	17	127	637	1.19
GEH45ES	GEG45ES	45	75	43	28	66	0.6	1	15	156	780	1.57
GEH50ES	GEG50ES	50	90	56	36	80	0.6	1	17	245	1220	2.51
GEH60ES	GEG60ES	60	105	63	40	92	1	1	17	313	1560	4.50
GEH70ES	GEG70ES	70	120	70	45	105	1	1	16	400	2000	6.60
GEH80ES	GEG80ES	80	130	75	50	115	1	1	14	488	2440	8.00
GEH90ES	GEG90ES	90	150	85	55	130	1	1	15	607	3030	11.50
GEH100ES	GEG100ES	100	160	85	55	140	1	1	14	654	3270	13.30
GEH110ES	GEG110ES	110	180	100	70	160	1	1	12	950	4750	21.30
GEH120ES	GEG120ES	120	210	115	70	180	1	1	16	1070	5350	30.80
GEH140ES	GEG140ES	140	230	130	80	200	1	1	16	1360	6800	42.00
GEH160ES	GEG160ES	160	260	135	80	225	1.1	1.1	16	1530	7650	44.00
GEH180ES	GEG180ES	180	290	155	100	250	1.1	1.1	14	2120	10600	71.00
GEH200ES	GEG200ES	200	320	165	100	275	1.1	1.1	15	2320	11600	99.00
GEH220ES	GEG220ES	220	340	175	100	300	1.1	1.1	16	2550	12700	112.50
GEH240ES	GEG240ES	240	370	190	110	325	1.1	1.1	15	3030	15190	143.00
GEH260ES	GEG260ES	260	400	205	120	350	1.1	1.1	15	3570	17850	182.00
GEH280ES	GEG280ES	280	430	210	120	375	1.1	1.1	15	3800	19100	214.00

Also available: Maintenance Free – PTFE Lined – GEH...TE 2RS, Stainless Steel – GEH...TE/X

Common Interchanges (100mm Bore): GE100FO, 100FSH160, GE100GS, MBH100



www.bl-bearings.com

# SPHERICAL PLAIN BEARINGS – METRIC

## GE...C & GEH...C SERIES

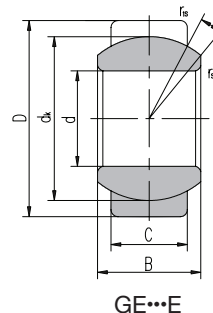

### Specifications

- Sliding Surface: PTFE Lined Steel Outer on Chrome Plated Ball
- Maintenance Free - Low Friction

Part #	Ref #	Dimensions (mm)								Load Ratings kN		Weight LBS
		d	D	B	C	d <sub>k</sub>	r <sub>s</sub> min	r <sub>is</sub> min	α ≈	Dynamic	Static	
GE4C	GE4C	4	12	5	3	8	0.3	0.3	16	2.1	5.4	.007
GE5C	GE5C	5	14	6	4	10	0.3	0.3	13	3.6	9.1	.008
GE6C	GE6C	6	14	6	4	10	0.3	0.3	13	3.6	9.1	.009
GE8C	GE8C	8	16	8	5	13	0.3	0.3	15	5.8	14	.018
GE10C	GE10C	10	19	9	6	16	0.3	0.3	12	8.6	21	.024
GE12C	GE12C	12	22	10	7	18	0.3	0.3	10	11	28	.033
GE15C	GE15C	15	26	12	9	22	0.3	0.3	8	18	45	.059
GE17C	GE17C	17	30	14	10	25	0.3	0.3	10	22	56	.090
GE20C	GE20C	20	35	16	12	29	0.3	0.3	9	31	78	.145
GE25C	GE25C	25	42	20	16	35.5	0.6	0.6	7	51	127	.262
GE30C	GE30C	30	47	22	18	40.7	0.6	0.6	6	65	166	.359

Common Interchanges (25mm Bore): GE25UK, GE 25C, GE25-D, GE25EC, GE25HWA, SAR1-25, BM25

Part #	Ref #	Dimensions (mm)								Load Ratings kN		Weight LBS
		d	D	B	C	d <sub>k</sub>	r <sub>s</sub> min	r <sub>is</sub> min	α ≈	Dynamic	Static	
GEH4C	GEG4C	4	14	7	4	10	0.3	0.3	20	3.6	9.1	.011
GEH5C	GEG5C	5	16	9	5	10	0.3	0.3	21	5.8	14	.018
GEH6C	GEG6C	6	16	9	5	13	0.3	0.3	21	5.8	14	.013
GEH8C	GEG8C	8	19	11	6	16	0.3	0.3	21	8.6	21	.030
GEH10C	GEG10C	10	22	12	7	18	0.3	0.3	18	11	28	.046
GEH12C	GEG12C	12	26	15	9	22	0.3	0.3	18	18	45	.073
GEH15C	GEG15C	15	30	16	10	25	0.3	0.3	16	22	56	.110
GEH17C	GEG17C	17	35	20	12	29	0.3	0.3	19	31	78	.183
GEH20C	GEG20C	20	42	25	16	35.5	0.3	0.3	17	51	127	.340
GEH25C	GEG25C	25	47	28	18	40.7	0.6	0.6	17	65	166	.450
GEH30C	GEG30C	30	55	32	20	47	0.6	0.6	17	83	212	.670

Common Interchanges (100mm Bore): GE25FW, GE25BW-A



# EXTENDED INNER RING – METRIC

## GEG SERIES

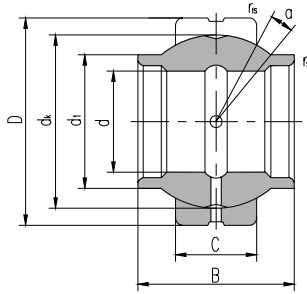

### Specifications

- Extended Inner Ring eliminating need for locational spacers
- Sliding Surface: Steel on Steel - MoS<sub>2</sub> treated
- Single Fracture Design
- Relubricatable through annular grooves & oil holes in inner & outer rings (ES – Suffix)

Part #	Ref #	Dimensions (mm)									Load Ratings kN		Weight LBS
		d	D	B	C	d <sub>i</sub> max	d <sub>k</sub>	r <sub>s</sub> min	r <sub>is</sub> min	α ≈	Dynamic	Static	
GEG12ES	GEEW12ES	12	22	12	7	15.5	18	0.3	0.3	4	10	53	0.022
GEG15ES	GEEW15ES	15	26	15	9	18.5	22	0.3	0.3	5	16	84	0.031
GEG16ES	GEEW16ES	16	28	16	9	20	23	0.3	0.3	4	17	85	0.035
GEG17ES	GEEW17ES	17	30	17	10	21	25	0.3	0.3	7	21	106	0.044
GEG20ES	GEEW20ES	20	35	20	12	25	29	0.3	0.3	4	30	146	0.071
GEG25ES	GEEW25ES	25	42	25	16	30.5	35.5	0.6	0.6	4	48	240	0.131
GEG30ES	GEEW30ES	30	47	30	18	34	40.7	0.6	0.6	4	62	310	0.168
GEG32ES	GEEW32ES	32	52	32	18	37	44	0.6	1	4	65	328	0.182
GEG35ES	GEEW35ES	35	55	35	20	40	47	0.6	1	4	79	399	0.253
GEG40ES	GEEW40ES	40	62	40	22	46	53	0.6	1	4	99	495	0.338
GEG45ES	GEEW45ES	45	68	45	25	52	60	0.6	1	4	127	637	0.481
GEG50ES	GEEW50ES	50	75	50	28	57	66	0.6	1	4	156	780	0.558
GEG60ES	GEEW60ES	60	90	60	36	68	80	1	1	4	245	1220	1.15
GEG63ES	GEEW63ES	63	95	63	36	71.5	83	1	1	4	253	1260	1.25
GEG70ES	GEEW70ES	70	105	70	40	78	92	1	1	4	313	1560	1.71
GEG80ES	GEEW80ES	80	120	80	45	91	105	1	1	4	400	2000	2.39
GEG90ES	GEEW90ES	90	130	90	50	99	115	1	1	4	488	2440	3.21
GEG100ES	GEEW100ES	100	150	100	55	113	130	1	1	4	607	3030	4.79
GEG110ES	GEEW110ES	110	160	110	55	124	140	1	1	4	654	3270	5.78
GEG125ES	GEEW125ES	125	180	125	70	138	160	1	1	4	950	4750	8.49
GEG160ES	GEEW160ES	160	230	160	80	177	200	1	1	4	1360	6800	16.5
GEG200ES	GEEW200ES	200	290	200	100	221	250	1.1	1.1	4	2120	10600	32.1
GEG250ES	GEEW250ES	250	400	250	120	317	350	1.1	1.1	4	3750	17800	99.1
GEG320ES	GEEW320ES	320	520	320	160	405	450	1.1	1.1	4	6200	30500	225

Common Interchanges (25mm Bore): GE25LO, MB25E, GE25BN-A





# EXTENDED INNER RING – METRIC

## GEM SERIES

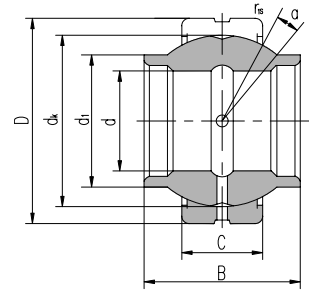

### Specifications

- Extended Inner Ring eliminating need for locational spacers
- Sliding Surface: Steel on Steel - MoS<sub>2</sub> treated
- Single Fracture Design
- Relubricatable through annular grooves & oil holes in inner & outer rings (ES – Suffix)

Part #	Ref #	Dimensions (mm)									Load Ratings kN		Weight LBS
		d	D	B	C	d <sub>i</sub> max	d <sub>k</sub>	r <sub>s</sub> min	r <sub>is</sub> min	α ≈	Dynamic	Static	
GEM20ES-2RS	GEEM20ES-2RS	20	35	24	12	24	29	0.3	0.3	6	30	146	.160
GEM25ES-2RS	GEEM25ES-2RS	25	42	29	16	29	35.5	0.3	0.6	4	48	240	.290
GEM30ES-2RS	GEEM30ES-2RS	30	47	30	18	34	40.7	0.3	0.6	4	62	310	.375
GEM35ES-2RS	GEEM35ES-2RS	35	55	35	20	40	47	0.6	1	4	79	399	.550
GEM40ES-2RS	GEEM40ES-2RS	40	62	38	22	45	53	0.6	1	4	99	495	.770
GEM45ES-2RS	GEEM45ES-2RS	45	68	40	25	52	60	0.6	1	4	127	637	1.08
GEM50ES-2RS	GEEM50ES-2RS	50	75	43	28	57	66	0.6	1	4	156	780	1.32
GEM60ES-2RS	GEEM60ES-2RS	60	90	54	36	68	80	0.6	1	3	245	1220	2.53
GEM70ES-2RS	GEEM70ES-2RS	70	105	65	40	78	92	0.6	1	4	313	1560	3.65
GEM80ES-2RS	GEEM80ES-2RS	80	120	74	45	90	105	0.6	1	4	400	2000	5.50

Common Interchanges (25mm Bore): GE25HO 2RS



# ANGULAR CONTACT SERIES

## GAZ SERIES – INCH

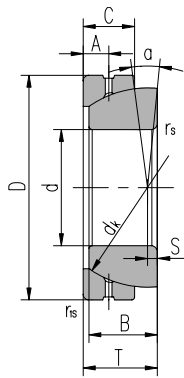

### Specifications

- Sliding Surface: Steel on Steel - MoS<sub>2</sub> treated
- Suitable for Radial loads and single direction Axial (Thrust) load
- Relubricatable through annular grooves & oil hole in outer ring

Part #	Ref #	Dimensions (mm/inch)										Load Ratings kN		Weight LBS
		d	D	B	C	T	d <sub>k</sub>	S	A	r <sub>s</sub> , r <sub>1s</sub> min	α ≈	Dynamic	Static	
GAZ 008SA	GACZ12S	0.5	0.875	0.27	0.19	0.3	0.719	0.051	0.094	0.02	7	6	18	.029
GAZ 010SA	GACZ15S	0.625	1.0625	0.34	0.25	0.37	0.899	0.058	0.109	0.03	6	10	31	.055
GAZ 012SA	GACZ19S	0.75	1.25	0.41	0.31	0.44	1.08	0.07	0.125	0.04	6	16	47	.084
GAZ 014SA	GACZ22S	0.875	1.4375	0.48	0.38	0.52	1.258	0.08	0.172	0.08	5.5	23	66	.110
GAZ 100SA	GACZ25S	1	1.625	0.55	0.44	0.6	1.437	0.1	0.203	0.08	6	29	87	.187
GAZ 104SA	GACZ31S	1.25	2	0.7	0.55	0.74	1.795	0.132	0.234	0.08	6	47	142	.300
GAZ 106SA	GACZ34S	1.375	2.1875	0.77	0.6	0.84	1.937	0.145	0.281	0.1	4	53	159	.467
GAZ 108SA	GACZ38S	1.5	2.4375	0.84	0.66	0.91	2.155	0.155	0.312	0.1	5.5	66	197	.660
GAZ 112SA	GACZ44S	1.75	2.8125	0.98	0.79	1.07	2.515	0.186	0.328	0.1	6	91	273	1.00
GAZ 200SA	GACZ50S	2	3.1875	1.13	0.92	1.23	2.875	0.217	0.375	0.14	5.5	122	365	1.47
GAZ 204SA	GACZ57S	2.25	3.5625	1.27	1.05	1.39	3.235	0.243	0.453	0.14	5.5	155	466	2.08
GAZ 208SA	GACZ63S	2.5	3.9375	1.42	1.18	1.54	3.59	0.267	0.5	0.14	5	196	589	2.49
GAZ 212SA	GACZ69S	2.75	4.375	1.56	1.275	1.7	3.95	0.294	0.515	0.18	5	231	694	3.85
GAZ 300SA	GACZ76S	3	4.75	1.71	1.405	1.86	4.312	0.322	0.578	0.18	5	279	838	5.02
GAZ 304SA	GACZ82S	3.25	5.125	1.86	1.545	2.03	4.675	0.356	0.656	0.18	5	332	995	6.40
GAZ 308SA	GACZ88S	3.5	5.5	2	1.675	2.18	5.04	0.374	0.703	0.18	4.5	389	1167	7.00
GAZ 312SA	GACZ95S	3.75	5.875	2.15	1.805	2.34	5.39	0.398	0.765	.018	4.5	449	1348	8.70
GAZ 400SA	GACZ101S	4	6.25	2.3	1.935	2.5	5.75	0.409	0.781	0.18	4.5	515	1545	10.50
GAZ 408SA	GACZ114S	4.5	7	2.59	2.195	2.8	6.475	0.488	0.875	0.18	4.5	663	1990	15.00
GAZ 500SA	GACZ127S	5	7.75	2.88	2.455	3.13	7.19	0.547	1.00	0.18	4.5	818	2455	22.10
GAZ 600SA	GACZ152S	6	8.75	3.1	2.615	3.375	8.156	0.634	1.37	0.18	4.5	985	2955	35.00

Common Interchanges (1" Bore): 10SBT16, B16SA



# ANGULAR CONTACT SERIES

## GAC...F SERIES – METRIC

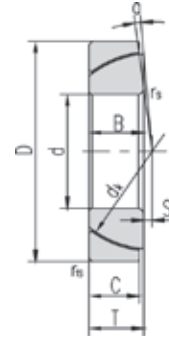

### Specifications

- Sliding Surface: PTFE Lined Steel Outer on Chrome Plated Ball
- Maintenance Free - Low Friction
- Suitable for Radial Loads and single direction Axial (Thrust) Loads

Part #	Ref #	Dimensions (mm)									Load Ratings kN		Weight LBS
		d	D	B	C	T	d <sub>k</sub>	S	r <sub>s</sub> , r <sub>is</sub> min	α ≈	Dynamic	Static	
GAC25F	GAC25T	25	47	15	14	15	42	0.6	1	2.5	75	149	.325
GAC28F	GAC28T	28	52	16	15	16	47	1	1	2	90	179	.410
GAC30F	GAC30T	30	55	17	15	17	49.5	1.3	1	4.5	95	188	.460
GAC32F	GAC32T	32	58	17	16	17	52	2	1	2	106	211	.530
GAC35F	GAC35T	35	62	18	16	18	55.5	2.1	1	4	117	234	.590
GAC40F	GAC40T	40	68	19	17	19	62	2.8	1	3.5	139	277	.720
GAC45F	GAC45T	45	75	20	18	20	68.5	3.5	1	3	162	324	.920
GAC50F	GAC50T	50	80	20	19	20	74	4.3	1	1.5	185	370	1.00
GAC55F	GAC55T	55	90	23	20	23	82	5	1.1	4	216	432	1.42
GAC60F	GAC60T	60	95	23	21	23	88.5	5.7	1.1	2.5	245	489	1.57
GAC65F	GAC65T	65	100	23	22	23	93.5	6.5	1.1	1	271	542	1.67
GAC70F	GAC70T	70	110	25	23	25	102	7.2	1.1	2	309	618	2.30
GAC75F	GAC75T	75	115	25	24	25	107	7.9	1.1	1	339	676	2.47
GAC80F	GAC80T	80	125	29	25.5	29	115	8.6	1.1	3.5	387	772	3.40
GAC85F	GAC85T	85	130	29	26.5	29	122	9.4	1.1	2	426	851	3.54
GAC90F	GAC90T	90	140	32	28	32	128.5	10.1	1.5	3.5	474	948	4.60
GAC95F	GAC95T	95	145	32	29.5	32	135	10.8	1.5	2	525	1049	4.88
GAC100F	GAC100T	100	150	32	31	32	141	11.6	1.5	0.5	577	1151	5.15
GAC105F	GAC105T	105	160	35	32.5	35	148	12.3	2	2	634	1267	6.45
GAC110F	GAC110T	110	170	38	34	38	155	13	2	3	695	1380	8.10
GAC120F	GAC120T	120	180	38	37	38	168	14.5	2	0.5	820	1630	8.73
GAC130F	GAC130T	130	200	45	43	45	188	18	2.5	1	1060	2130	13.02
GAC140F	GAC140T	140	210	45	43	45	198	19	2.5	1	1120	2240	13.92
GAC150F	GAC150T	150	225	48	46	48	211	20	3	1	1280	2550	17.60
GAC160F	GAC160T	160	240	51	49	51	225	20	3	1	1445	2900	20.72
GAC170F	GAC170T	170	260	57	55	57	246	21	3	1	1780	3560	27.00
GAC180F	GAC180T	180	280	64	61	64	260	21	3	1	2090	4170	38.30
GAC190F	GAC190T	190	290	64	62	64	275	26	3	0.5	2250	4490	40.00
GAC200F	GAC200T	200	310	70	66	70	290	26	3	1.5	2520	5040	49.50

Common Interchanges (1" Bore): GE 100SW



# SPHERICAL PLAIN THRUST BEARINGS

## GX...T SERIES – METRIC

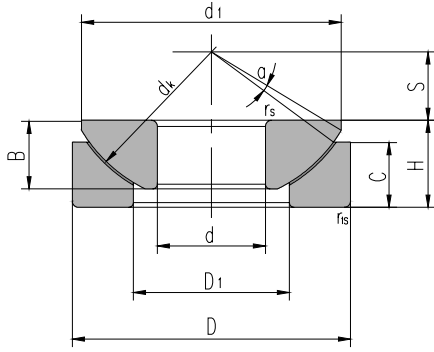

### Specifications

- Sliding Surface: PTFE Lined Steel Outer on Chrome Plated Ball
- Maintenance Free - Low Friction
- Suitable for single direction Axial (Thrust) Loads or combined Axial & Radial loads

Part #	Ref #	Dimensions (mm)											Load Ratings kN		Weight LBS
		d	D	B	C	H	dk	S	d <sub>1</sub> max	D <sub>1</sub> min	r <sub>s1</sub> r <sub>1s</sub> min	α ≈	Dynamic	Static	
GX 10F	GX10T	10	30	7.5	7	9.5	32	7	27.5	15.5	0.6	5	45	90	.079
GX 12F	GX12T	12	35	9.5	9.3	13	38	8	32	18	0.6	5	65	130	.158
GX 15F	GX15T	15	42	11	10.8	15	46	10	39	22.5	0.6	6	95	190	.237
GX 17F	GX17T	17	47	11.8	11.2	16	52	11	43.5	27	0.6	4	110	220	.30
GX 20F	GX20T	20	55	14.5	13.8	20	60	12.5	50	31	1	5	150	300	.541
GX 25F	GX25T	25	62	16.5	16.7	22.5	68	14	58.5	34.5	1	5	245	490	.913
GX 30F	GX30T	30	75	19	19	26	82	17.5	70	42	1	5	335	670	1.35
GX 35F	GX35T	35	90	22	20.7	28	98	22	84	50.5	1	5	490	980	2.15
GX 40F	GX40T	40	105	27	21.5	32	114	24.5	97	59	1	6	675	1350	3.50
GX 45F	GX45T	45	120	31	25.5	36.5	128	27.5	110	67	1	6	915	1830	4.93
GX 50F	GX50T	50	130	33	30.5	42.5	139	30	120	70	1	6	1040	2080	6.91
GX 60F	GX60T	60	150	37	34	45	160	35	140	84	1	6	1400	2800	10.19
GX 70F	GX70T	70	160	42	36.5	50	176	35	153	94.5	1	3	1590	3180	11.81
GX 80F	GX80T	80	180	43.5	38	50	197	42.5	172	107.5	1	4	1980	3920	15.20
GX 100F	GX100T	100	210	51	46	59	222	45	198	127	1.1	4	2270	4540	24.00
GX 120F	GX120T	120	230	53.5	50	64	250	52.5	220	145	1.1	3	2560	5720	30.58
GX 140F	GX140T	140	260	61	54	72	274	52.5	243	177	1.5	3	3050	6100	39.82
GX 160F	GX160T	160	290	66	58	77	313	65	271	200	1.5	2	3520	6250	51.04
GX 180F	GX180T	180	320	74	62	86	340	67.5	299	225	1.5	4	4070	7220	68.00
GX 200F	GX200T	200	340	80	66	87	365	70	320	247	1.5	1	4780	9150	75.24

Common Interchanges (100mm Bore): GE100AW



## HEAVY EQUIPMENT

### Dump Trucks

- Hinge Pin between truck bed & frame – GEZ Series
- Mobile Hydraulic Cylinders: Clevis on one or both ends of cylinder - GE/GEZ Series



### Front End Loaders

- Clevis/Shovel Connection – GEZ Series
- Articulated Joint – GEZ Series
- Mobile Hydraulic Cylinders: Clevis on one or both ends of cylinder – GE/GEZ Series



### Logging Machinery

- King Pin Assemblies – GAZ...SA
- Tie Rod – GEG or GEM (extended inner ring eliminates need for spacers)



### Shuttle Cars (Mining)

- GAZ...SA angular contact



### Wind Mills

- GAZ...Series angular contact

### Fork Lifts

- Steering Axel, Drag Link, & King Pin on steering assemblies – GE/GEZ Series
- Tilt Cylinders guiding the forward/backward movement of the mast – GEZ Series



### Textile Industry Extractors

- Suspension rods (misalignment) – GE Series

### Overhead Carrier

- Eyebolt – GEZ & GAZ...SA angular contact

### Chain Conveyor

- Chain Link top plates – GEZ
- Chain Link anchor plates (thrust loads) – GAZ...SA



# TECHNICAL INFORMATION

## Operating Temperatures

The operating temperature range for Spherical Plain Bearings with seals is -20° to +250°F. The operating range for Spherical Plain Bearings without seals is -50° to +300°F.

## Lubrication

Steel-on-steel Spherical Plain Bearings are coated with MoS<sub>2</sub> dry lubricant & can be operated without lubrication when the magnitude of applied load is small and the sliding velocity of oscillation is small. In other applications, it is necessary to lubricate periodically with grease or oil. During initial operations, it is recommended to shorten the lubrication interval. Lithium soap base grease (NLGI consistency No. 2) containing molybdenum disulfide (MoS<sub>2</sub>) is recommended as the lubricating grease.

When operating conditions are such that enhanced sealing protection against dust, contaminants or corrosive elements is required, the bearings can be effectively protected if the space around the bearing is filled with grease.

## Internal Clearance

Internal clearance is defined as the total distance through which one ring can be moved radially or axially in relation to the other ring under a defined load. It is necessary to distinguish between the clearance before it is mounted, and the clearance of a mounted bearing. The unmounted clearance will always be greater than the operational clearance because the rings are expanded or compressed by interference fits of mating components.

Bearings are produced with standard “normal” clearance so that when bearings are mounted as generally recommended and operate under normal conditions, a suitable operational clearance will be obtained. For other conditions; for example when both rings are mounted with an interference fit, or where unusual temperatures prevail; bearings with a greater or smaller internal clearance may be required.

Standard “normal” clearances vary by series. Contact factory if actual clearance data is required.

## Shaft & Housing Fits of Radial Spherical Plain Bearings

### Shaft Fits

Operating Conditions	Sliding Contact	
	Steel on Steel	Maintenance Free
Normal Operation – Clearance/Transition Fit	h6	h6, g6
Normal Operation – Interference Fit	m6	k6

Consult factory for actual values corresponding to above fits

### Housing Fits

Operating Conditions	Sliding Contact	
	Steel on Steel	Maintenance Free
Light Loads (axial displacement required)	H7	H7
Heavy Loads	M7	K7
Light Alloy Housings	N7	M7

## Tolerances

### Tolerances for Radial Spherical Plain Bearings

Unit: μm

Nominal Bore or Outside Diameter mm		Δdmp Single plane mean bore dia. deviation		ΔDmp Single plane mean outside dia. Deviation*		ΔBs Inner ring width deviation		ΔCs Outer ring width deviation	
Over	Incl.	Max	Min	Max	Min	Max	Min	Max	Min
2.5	6	0	-8	0	-	0	-120	0	-240
6	18	0	-8	0	-8	0	-120	0	-240
18	30	0	-10	0	-9	0	-120	0	-240
30	50	0	-12	0	-11	0	-120	0	-240
50	80	0	-15	0	-13	0	-150	0	-300
80	120	0	-20	0	-15	0	-200	0	-400
120	180	0	-25	0	-18	0	-250	0	-500
180	250	0	-30	0	-30	0	-300	0	-600
250	315	0	-35	0	-35	0	-350	0	-700
315	400	0	-40	0	-40	0	-400	0	-800

\* Tolerances apply to outer rings without surface treatment and splitting. The outer rings become slightly out-of-round due to splitting. The roundness is restored once it is fitted in a housing bore produced in accordance with the specifications. Measurements taken of the outside diameter of the unfitted bearing cannot be used as the original actual values for the outside diameter.



## SPHERICAL PLAIN BEARING INTERCHANGE

BL #	Imp	SKF	RBC	TOR	ELGES / FAG / INA	IKO	NTN	ASK	Spherco
Radial Inch									
GEZ 100ES	GEZ25ES	GEZ100ES	B16L	10SF16	GE25ZO	SBB16	SA2-16B	SA2-16B	
GEZ 100TE 2RS	GEZ25ET-2RS	GEZ100TE-2RS	B100LNMSS	10SFL16TT			SAR2-16		
COM 8	GEFZ12S	-	CRS 8 (Old #)	-	-	-	-	-	SBG8S
GEZM 100ES	GEWZ25ES	GEZM100ES	B16EL	-	-	-	-	-	
GEZH 200ES	GEZ50ES	GEZH200ES	BH3236L	-	-	-	-	-	

Radial Metric									
GE 25ES	GE25ES	GE25ES	MB25	25FS42	GE25DO	GE25ES	SA1-25B	GE25	
GE 25C	GE25C	GE25C	SAR1-25	GE25-D	GE25UK	GE25EC	SAR1-25*	BM25	
GE 25TE 2RS	GE25ET-2RS	GE25TE-2RS	SAR1-25SS	GE25D-2RS	GE25UK-2RS	GE25EC-2RS	SAR1-25SS		
GEH 25C	GEG25C	GEH25C			GE25FW				
GEH 25ES	GEG25ES	GEH25ES	MBH2530	25FSH47	GE25FO	GE25GS	-	-	
GEH 25TE 2RS	GEG25ET-2RS	GEH25TE-2RS	-	-	GE25FW-2RS	-	-	-	
GEM 25ES 2RS	GEM25ES-2RS	GEM25ES-2RS	-	-	GE25HO-2RS	-	-	-	
GEG 25ES	GEEW25ES	GEG25ES	MB25E	-	GE25LO	GE25BN-A	-	-	

Angular Contact									
GAC 25F	GAC25T	GAC25F	MB25SA**	-	GE25SW	-	-	-	
GAZ 200SA	GACZ50S	GAZ200SA	B32SA	20SBT32	-	-	-	-	

Thrust									
GX 25F	GX25T	GX25F	-	-	GE25AW	-	-	-	
GX 25	GX25S	-	-	-	-	-	SAT25	-	

\* NTN Bearing - Only ball is chrome \*\* RBC is made Re-lube type, not maintenance free like others

This chart is prepared to assist in comparing the interchangeability between manufacturers & should be used as a guide only. Efforts have been made to ensure its accuracy. Please contact representative to assist in comparing dimensions critical for specific applications



BEARINGS

SPROCKETS

BUSHINGS

MOUNTED  
UNITS &  
INSERTS

CHAIN

WE MAKE  
IT MOVE



BL Bearings • 2100 Pacific Street • Hauppauge, NY 11788 • 631-273-8200 • [www.bl-bearings.com](http://www.bl-bearings.com)