

# **Martin** ELITE SERIES

**Improved Performance**  
**Profiled Integral End Plate**  
**Submerged Arc Welding**



*Martin* Elite Series Pulleys are engineered to offer an efficient and improved alternative to standard stock Drum Pulleys. *Martin* Elite Series Pulleys simplify the selection as they can be used in a wide range of applications from standard, mine and quarry duty, thus reducing your replacement inventory. Instead of deciding what might be the best pulley for your application, now you have one choice that conveys them all.

*Martin* Elite Series Pulleys are designed to meet today's demanding applications by offering the following standard benefits:

- **Profiled Integral End Plate**

- » True-Turbine profile end plates that distribute stress more evenly.
- » Moves stress away from the hub and reduces the risk of failure.

- **Weldment**

- » Submerged arc welding with machined-in weld preparation provides maximum weld penetration.

- **Optimization**

- » Stocked with MXT Bushings but available for Keyless Locking Devices.

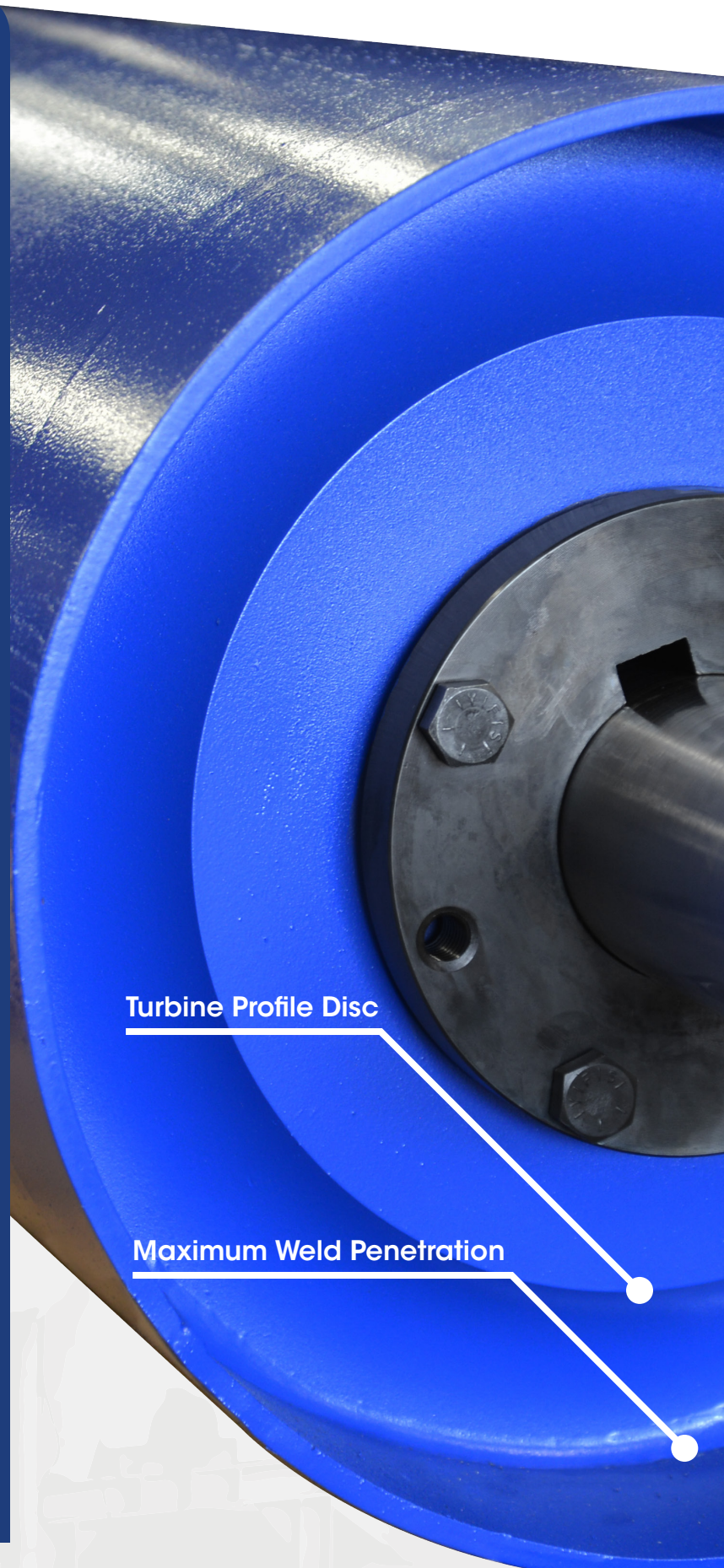

Turbine Profile Disc

Maximum Weld Penetration

True Turbine Profile

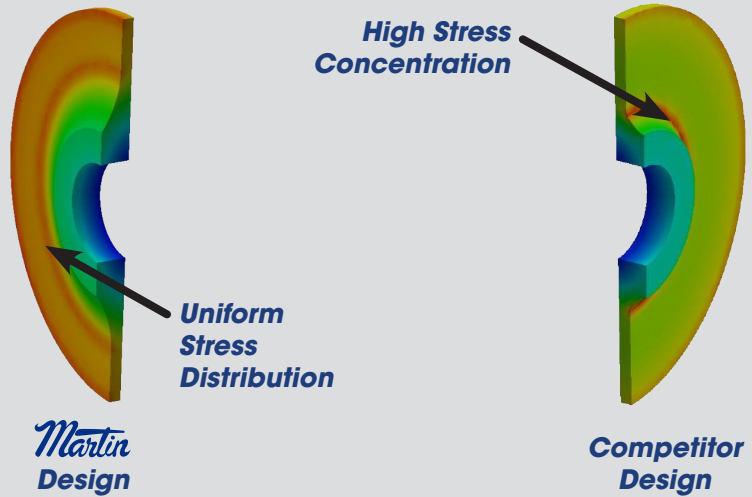

- Eliminates hub welds
- Smooth arc profile
  - » Removes high stress concentrations
  - » Distributes stresses uniformly
- Truly flexible end disc
  - » Keeps the bushing square to the bore and shaft
- Moves stress away from the hub
  - » Reduces the chance for hub fracture
  - » Excellent fatigue life
- Submerged arc weld to rim

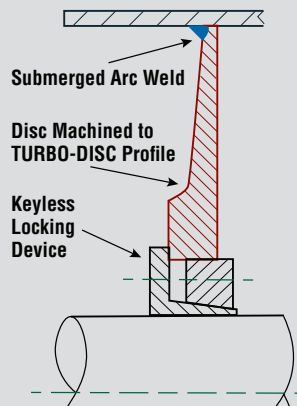

**Martin Elite Series Pulley** with submerge arc weld that provides added strength at high stress points because of the deeper penetration provided by the machined-in weld preparation.

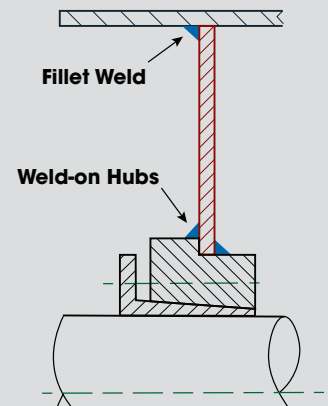

**Traditional Competitor Drum Pulley** has fillet weld at the connection of end-disc to shell and end-disc to hub.

# C MES 12 26 X25 L 3 H

### Face

- C** Crown
- F** Flat

### Martin Elite Series

### Diameter 2 digits

**12** 12"

### Face Width 2 digits

**26** 26"

### Hub Size

### Lagging and "L" if lagged

### Lagging Thickness in 8th, 1 digit

**3** 3/8"

### Lagging Style if no letter, lagging is smooth

- H** Herringbone
- D** Diamond Groove
- C** Ceramic (no thickness specified)
- S** Slide Lagging (no thickness specified)

**USA** **Corporate Offices**  
**Sales & Manufacturing**  
 Arlington, TX  
 817-258-3000 (FAX 817-258-3333)

### Regional Manufacturing Plants

Albemarle, NC  
 704-982-9555 (FAX 704-982-9599)  
 Atlanta, GA  
 404-292-8744 (FAX 404-292-7771)  
 Burleson, TX  
 817-295-7151 (FAX 817-447-3840)  
 Danielsville, PA  
 610-837-1841 (FAX 610-837-7337)  
 Ft. Worth, TX  
 817-258-3000 (FAX 817-258-3173)  
 Montpelier, OH  
 419-485-5515 (FAX 419-485-3565)  
 Sacramento, CA  
 916-441-7172 (FAX 916-441-4600)

### Branch Manufacturing Plants

Boston, MA  
 508-634-3990 (FAX 508-634-3998)  
 Charlotte, NC  
 704-394-9111 (FAX 704-394-9122)  
 Chicago, IL  
 847-298-8844 (FAX 847-298-2967)  
 Denver, CO  
 303-371-8466 (FAX 303-371-7116)  
 Houston, TX  
 713-849-4330 (FAX 713-849-4807)  
 Kansas City, MO  
 816-231-5575 (FAX 816-231-1959)  
 Los Angeles, CA  
 323-728-8117 (FAX 323-722-7526)  
 Minneapolis, MN  
 952-829-0623 (FAX 952-944-9385)  
 Nashville, TN  
 615-871-4730 (FAX 615-871-4125)  
 Pittsburgh, PA  
 724-452-4555 (FAX 724-452-5794)  
 Portland, OR  
 503-223-7261 (FAX 503-221-0203)  
 Tampa, FL  
 813-623-1705 (FAX 813-626-8953)

### Manufacturing Only

Abilene, TX • Clarksville, TX  
 Dallas, TX • Mansfield, TX  
 Paragould, AR

**CANADA**  
 Cambridge, Ontario  
 519-621-0546 (FAX 519-621-4413)  
 Edmonton, Alberta  
 780-450-0888 (FAX 780-465-0079)  
 Mississauga, Ontario  
 905-670-1991 (FAX 905-670-2110)

**MEXICO**  
 Guadalajara, JAL  
 +52 33-3283-1188  
 (FAX +52 33-3271-8450)  
 Monterrey, N.L.  
 +52 811 156 6830  
 (FAX +52 81-1156-6833)  
 Toluca, MEX  
 +52 722 276 0800  
 (FAX +52 722-276-0801)

**BRAZIL**  
 São Paulo, SP  
 +55 19 3877 9400  
 (FAX +55 19-3877-9429)

[martinsprocket.com](http://martinsprocket.com)

Martin Sales and Engineering will work with you to completely solve your belt conveying needs. Since there are infinite amounts of conveying possibilities and configurations our sales and engineering staff are prepared to assist you with a custom solution.

Call *Martin*, we will be happy to assist you!

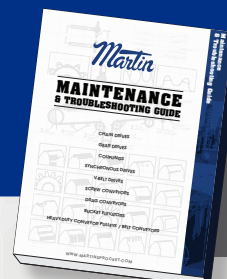

**Free Download**  
**Maintenance &**  
**Troubleshooting**  
**Guide**

Scan to download

