

MOUNTED BALL BEARINGS



As regulations and consumers continue to encourage manufacturers for more stringent food safety requirements, producers must take a proactive approach to controlling and preventing food borne illnesses. Having the right processes in place and equipment that is designed around food safety principles is critical.

Aggressive cleaning and sanitation practices are necessary. These processes can be extremely tough on equipment and have devastating and far reaching effects on a company's reputation and profits. To ensure uptime, don't let bearings be the weak link in your production chain. FoodSafe™ bearings can improve reliability for your clean-in-place procedures and provide you the assurance needed. FoodSafe bearings solve two of the most prominent industry challenges that occur with bearings - grease washout and corrosion. We conquer these challenges with advanced designs and back our products with an unprecedented 1-year warranty from failure due to water ingress.



IP69 RATED for water and backed by an unprecedented 1-year warranty against failure due to water ingress



Housing Style	Standard housing	Stand-off housing
Pillow block	x	x
Tapped base	x	x
Two-bolt flange	x	x
Four-bolt flange	x	x
Flanged bracket (3-bolt)	x	x
Wide slot take-up	x	
Narrow slot take-up	x	

FoodSafe bearings

Improved cleanability for clean-in-place applications

Housing

Smooth housing without a grease zerk designed to minimize harboring points

Laser identification

Minimizes crevices that can harbor bacteria

Reduced maintenance

Sealed bearings

Sealed and lubed for life design minimizes maintenance costs

Extended life

Hydro armor seal

Protects internal rotating elements from water ingress

Maxlife cage

Prevents grease washout

H1 food grade lubricant

Lubed for life with synthetic food grade lubricant

KleenTec insert

Enhanced corrosion resistance from common cleaning agents

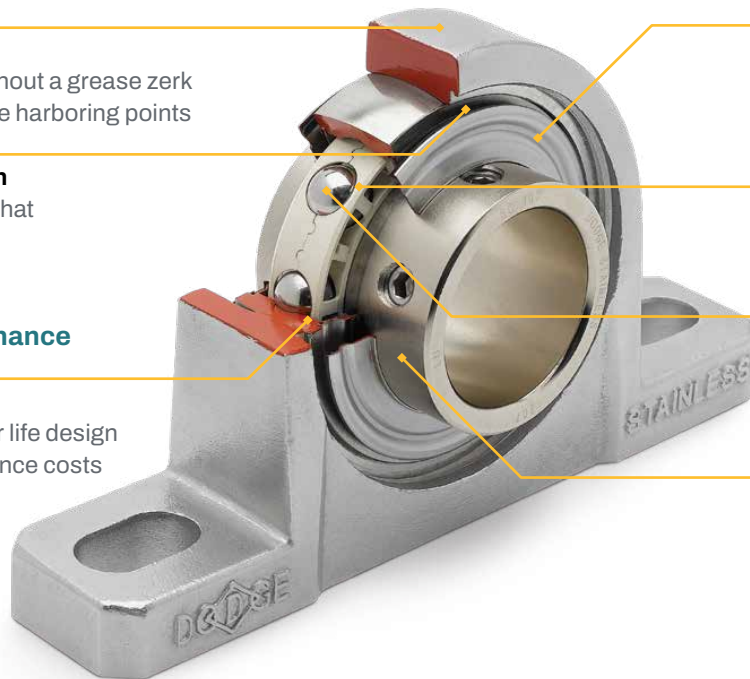

Stand-off bearing additional features

Housing

½" integral stand-off



Backside seal option

Field installable for additional protection (optional)

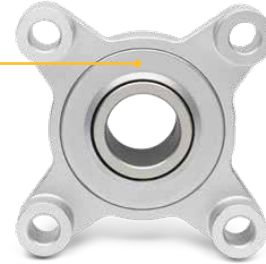

Dodge Industrial, Inc.

1061 Holland Road, Simpsonville, SC 29681
+1 864 297 4800

dodgeindustrial.com

Dodge Industrial, Inc. reserves all rights in this document and in the subject matter and illustrations contained therein. We reserve the right to modify contents without prior notice and do not accept responsibility for potential errors or possible lack of information in this document. Any reproduction, disclosure to third parties or utilization of its contents—in whole or in parts—is forbidden without prior written consent of Dodge Industrial, Inc.

© Copyright Dodge Industrial, Inc. All rights reserved. Specifications subject to change without notice.
An RBC Bearings company.

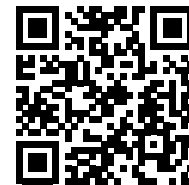

Watch our video to find out more.