



KABELSCHLEPP

PRODUCT PORTFOLIO



Cable Carrier Systems
TRAXLINE® Cables for motion
TOTALTRAX® Complete Systems

Solid nylon cable carriers with standard chain widths

STANDARD APPLICATIONS



Sub-division
simple



Additional load
up to 15 kg/m



Inner height
4.6 – 45 mm



Travel length unsupported
up to 7 m



Inner widths
6 – 250 mm



Travel speed
up to 25 m/s



Pitch
10 – 66.5 mm



Acceleration
up to 200 m/s²

Technical features:

- Economically priced solutions for standard applications
- Series and types with fixed or openable brackets
- Various types and designs directly available from stock
- Simple cable installation
- Simple cable installation by just pressing the cables into the carrier
- Ideal for short travel lengths and high travel speeds

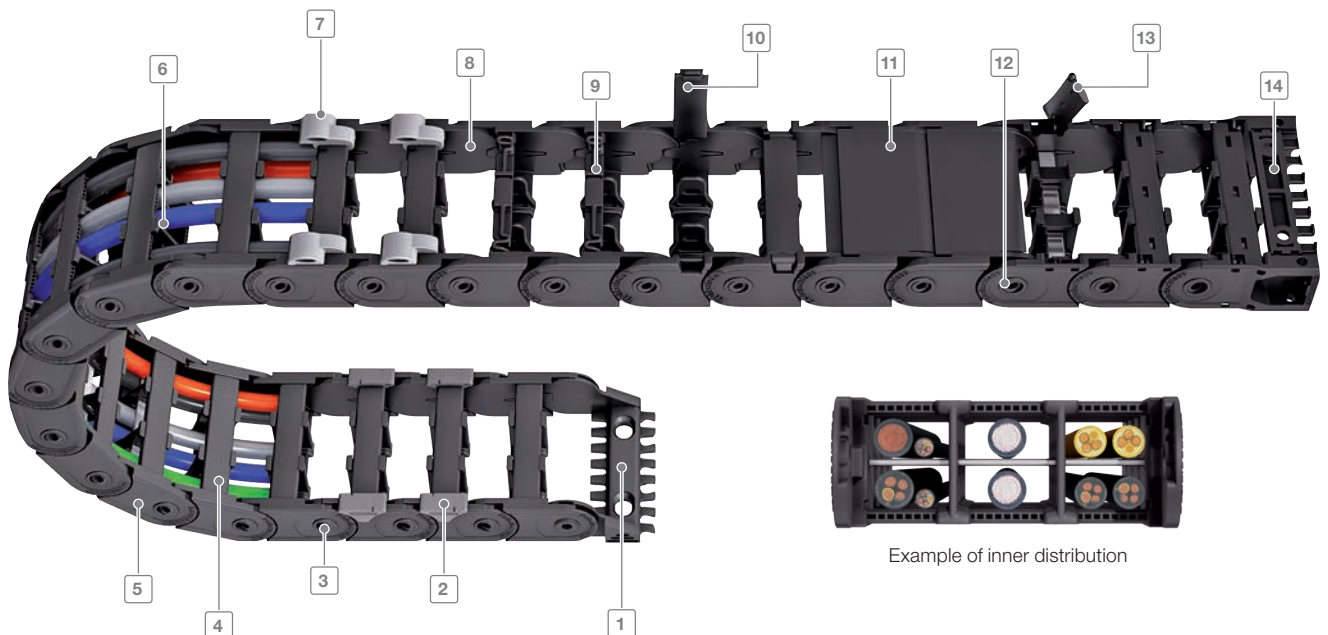



Our basic program includes different product types with simple design and predefined chain widths. All product types combine robustness and reliability with an excellent price-performance ratio. Cables can be quickly and easily installed into these carriers. Covered and fully enclosed product types guarantee optimum protection of cables and hoses against chips and other coarse dirt.

- 1 End connector with integrated strain relief
- 2 Replaceable glide shoes for longer life
- 3 Robust, double stroke system for longer self-supporting lengths
- 4 Non-opening links available
- 5 Chain links made of nylon
- 6 Vertical and horizontal separation for the cables
- 7 Outer noise dampening elements
- 8 Smooth internal edges to insure maximum cable life
- 9 Fast and easy cable installation by simply pressing in the cables
- 10 Swiveling brackets for quick cable installation available
- 11 Optional lids available in nylon that can be opened from inside or outside radius
- 12 Integrated noise dampening
- 13 Completely detachable brackets/covers available
- 14 Universal mounting bracket (UMB) with integrated strain relief

MONO series

Cable carrier with simple design for standard applications



Inner heights
10 – 15 mm



Inner widths
6 – 40 mm



Pitch
13 – 20 mm



Additional load
up to 1.3 kg/m



Travel length unsupported
up to 2 m



Travel length gliding
up to 70 m



Travel speed
up to 10 m/s



Acceleration
up to 50 m/s²

Technical features:

- Cost-effective cable carrier
- Simple and quick assembly
- Almost all types available immediately from stock all around the world
- Long service life
- High torsional rigidity
- Easy to install
- Long self-supporting length for its size class



QuickTrax series

Compact and cost-effective cable carrier in two-component “2K” technology



Inner height
20 mm



Inner widths
15 – 50 mm



Pitch
32 mm



Additional load
up to 3 kg/m



Travel length unsupported
up to 3 m



Travel length gliding
up to 80 m



Travel speed
up to 10 m/s



Acceleration
up to 50 m/s²









Technical features:

- Extremely fast and easy cable installation thanks to film hinge crossbars
- Extremely low noise due to integrated noise damping
- Long self-supporting length
- Sturdy two-component design provides solid cable carrier body with film hinge lid
- Sturdy chain design
- High torsional rigidity



UNIFLEX *Advanced* series

Designed with integrated noise dampening for use in a wide range of applications

| | | | |
|---|---|---|--|
|  Inner heights 20 – 44 mm |  Inner widths 15 – 250 mm |  Pitch 32 – 66.5 mm |  Additional load bis 15 kg/m |
|  Travel length unsupported up to 7 m |  Travel length gliding up to 150 m |  Travel speed up to 10 m/s |  Acceleration up to 50 m/s ² |

Technical features:

- Universal connection options
- Many possibilities for internal subdivision
- Long self-supporting length
- High torsional rigidity
- Low noise emissions
- Simple and fast cable installation
- Numerous custom material types for custom applications available

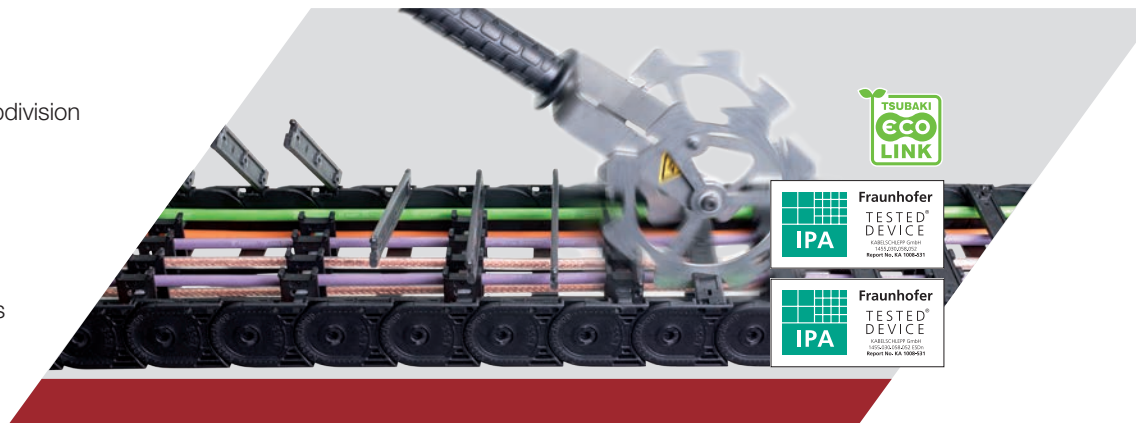

TKP35 series

Robust cable track for a multitude of applications

| | | | |
|---|--|--|--|
|  Inner height 32 mm |  Inner widths 16 – 50 mm |  Pitch 35 mm |  Additional load up to 2 kg/m |
|  Travel length unsupported up to 2.4 m |  Travel speed up to 5 m/s |  Acceleration up to 20 m/s ² | |

Technical features:

- Robust design with rigid stroke system
- Long self-supporting length
- Low noise operation due to internal damping system
- Weight-optimized cable carrier geometry
- Adjustable inner dividers
- Quick and easy to open
- Optional strain relief can be completely integrated into the connecting element



EasyTrax series

Extremely fast cable installation thanks to flexible crossbars

 **Inner heights**
4.6 – 31 mm

 **Inner widths**
7 – 78 mm

 **Pitch**
11.5 – 45.5 mm

 **Additional load**
up to 6 kg/m

 **Travel length unsupported**
up to 4.8 m

 **Travel length gliding**
up to 80 m

 **Travel speed**
up to 10 m/s

 **Acceleration**
up to 50 m/s²

Technical features:

- Simple and fast cable installation thanks to flexible lid design
- Extremely low noise due to integrated noise damping
- Very high fill level due to the crossbar pivoting to the side
- Sturdy two-component design provides solid cable carrier body with flexible film hinge lid
- High torsional rigidity
- Sturdy chain design
- Extensive unsupported length

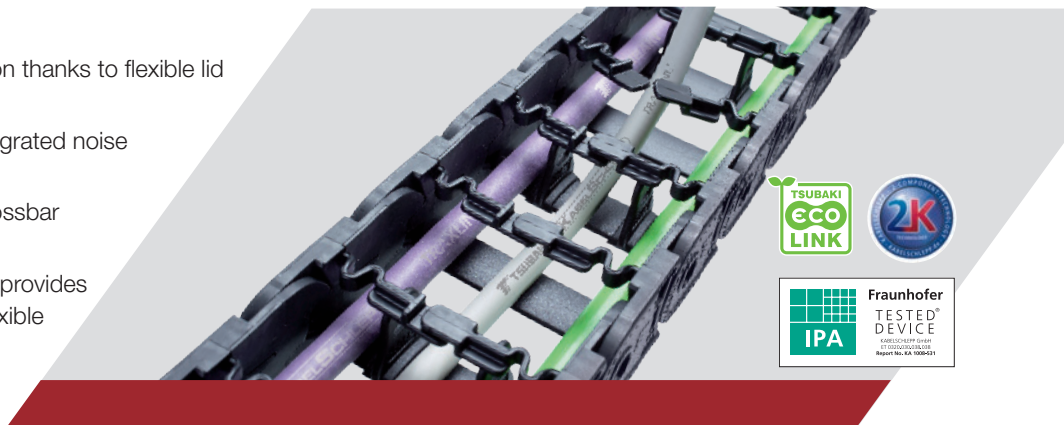

PROTUM series

Small, light cable carrier for unsupported applications

 **Inner heights**
10 – 25 mm

 **Inner widths**
15 – 50 mm

 **Pitch**
16 – 30 mm

 **Additional load**
up to 0.8 kg/m

 **Travel length unsupported**
up to 1.8 m

 **Travel speed**
up to 25 m/s

 **Acceleration**
up to 200 m/s²

Technical features:

- Quiet operation through short pitch
- Low-vibration operation
- Gentle on the cables as almost no polygon effect
- Cost savings through simple cable installation
- Easy adaptation of cable carrier length
- Ideal for short travel lengths and high travel speeds

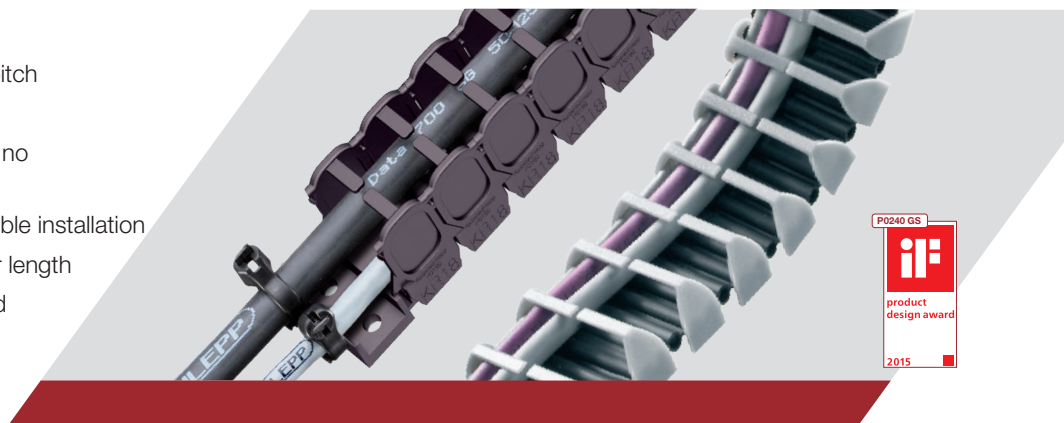

TKZP series

Small light weight cable carrier



Inner height
13 mm



Inner widths
10 – 15 mm



Pitch
10 mm



Additional load
up to 0.1 kg/m



Travel length unsupported
up to 1 m



Travel speed
up to 1.66 m/s



Acceleration
up to 5 m/s²

Technical features:

- Easy installation of cables and hoses due to folding structure
- Flexible design allows for lateral movement
- Easy adjustment of the profile length
- Compact external dimensions for very restricted installation areas
- Low noise operation due to short pitch and extruded profile



TKA series

Enclosed cable carrier – IP54 certified*



Inner heights
20.5 – 45 mm



Inner widths
15 – 250 mm



Pitch
30.5 – 55.5 mm



Additional load
up to 10 kg/m



Travel length unsupported
up to 6.5 m



Travel length gliding
up to 150 m



Travel speed
up to 9 m/s



Acceleration
up to 45 m/s²

Technical features:

- Excellent cable protection
- Chip/dirt resistant due to smooth surfaces
- Simple and fast installation is possible
- Easy-to-open cover with simultaneously high retention force on the chain link during operation
- Long self-supporting length
- Low noise emissions
- Easy assembly

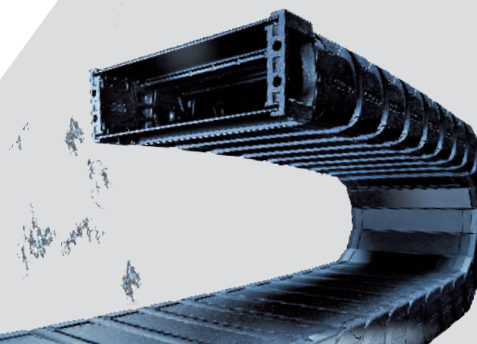

* Refers to type TKA55 with B, 50 – 175. More information about certification can be found at: kabelschlepp.de/tka-ip54

Cable and hose carrier systems with variable chain widths

ADVANCED APPLICATIONS



Sub-division
complex



Additional load
up to 65 kg/m

Technical features:

- Aluminum stays in 1 mm width sections
- Plastic stays in 4, 8, 16 mm width increments (depending on type)
- Quick and easy opening to the inside or outside radius
- Light, extremely robust or linkless series
- The right solution for demanding applications



Inner heights
19 – 108 mm



Travel length unsupported
up to 9.9 m



Inner widths
20 – 1000 mm



Travel speed
up to 40 m/s



Pitch
15 – 165 mm



Acceleration
up to 300 m/s²

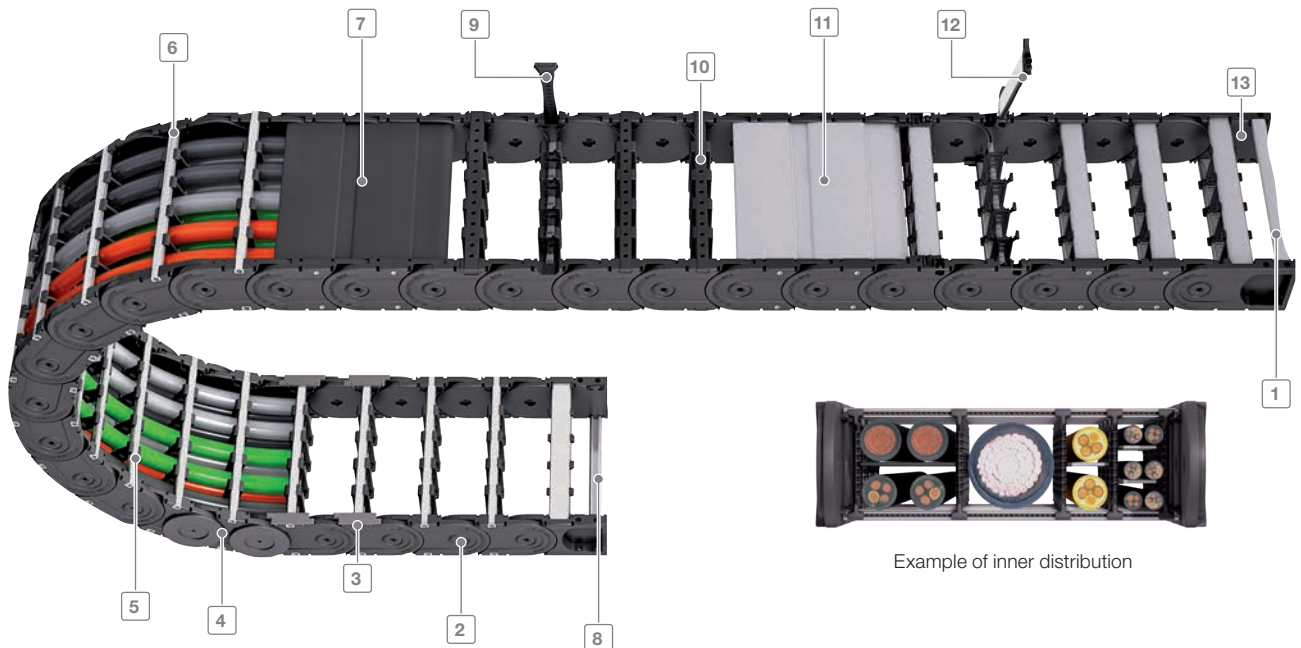



Would you like something extra? These types of products offer more variability in chain width and more separation options within the cable carrier compared to our standard program. Thus, a safe and efficient devising is possible even for the most complex cable configurations. Hoses and cables with large diameters can also be easily accommodated and guided. Enclosed systems provide optimum protection.

- 1 C-rail for strain relief elements
- 2 Minimized hinge wear owing to the “life extending 2 disc principle”
- 3 Replaceable glide shoes
- 4 Extremely robust due to strong side plate construction
- 5 Large choice of ways of separating the cables
- 6 Aluminum stays available in 1 mm width sections
- 7 Plastic cover available in 8 or 16 mm width sections
- 8 Integratable strain relief (strain relief comb without illustration)
- 9 Can be opened quickly on the inside or the outside for cable installation
- 10 Plastic stays available in 4, 8 or 16 mm width sections
- 11 Aluminum cover available in 1 mm width sections
- 12 Aluminum stays with ball-joint mechanism
- 13 Universal end connectors (UMB)

WIDTH INCREMENTS

Aluminum stays and covers available in custom widths to the exact millimeter.

K series

Cost-effective, robust cable carrier – also suitable for heavy loads



Inner heights
38 – 58 mm



Inner widths
68 – 561 mm



Pitch
65 – 90 mm



Additional load
up to 30 kg/m



Travel length unsupported
up to 7.7 m



Travel length gliding
up to 260 m



Travel speed
up to 8 m/s



Acceleration
up to 40 m/s²

Technical features:

- Enclosed stroke system that is protected from the effects of dirt and contamination
- Durable sidebands with robust link plate design
- Can be opened on the inside and outside radius
- Integrated glide base



B₁ increments
1 mm

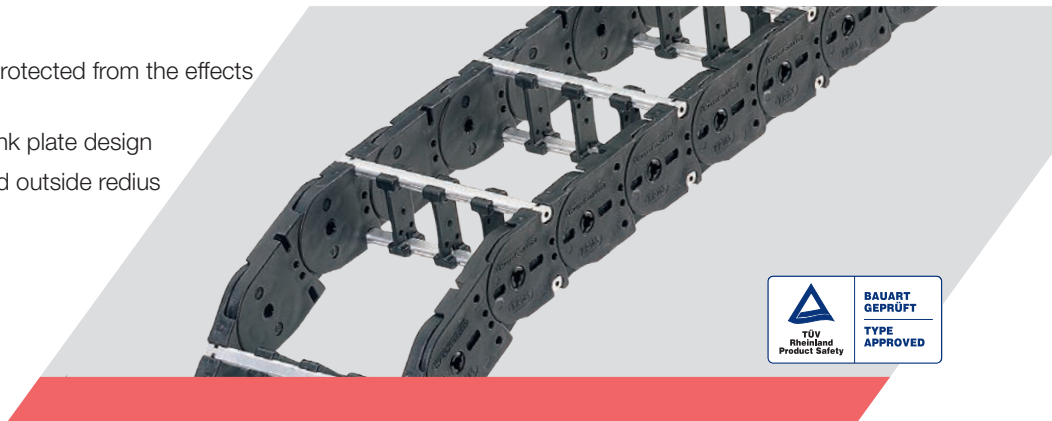

MASTER / MASTER-Tubes series

Quiet and weight-optimized cable carrier



Inner heights
33 – 80 mm



Inner widths
50 – 800 mm



Pitch
56 – 111 mm



Additional load
up to 25 kg/m



Travel length unsupported
up to 7.9 m



Travel length gliding
up to 80 m



Travel speed
up to 10 m/s



Acceleration
up to 50 m/s²

Technical features:

- For cables with large cable diameter
- Good ratio between inner and outer width dimensions
- Low chain weight
- Aluminium cover system available











B₁ increments
1 mm



M / M-Tubes series

Variable cable carrier with extensive accessories and crossbar variants

| | | | |
|---|---|---|--|
|  Inner heights 19 – 87 mm |  Inner widths 24 – 800 mm |  Pitch 32 – 130 mm |  Additional load up to 65 kg/m |
|  Travel length unsupported up to 9.9 m |  Travel length gliding up to 300 m |  Travel speed up to 10 m/s |  Acceleration up to 50 m/s ² |

Technical features:

- Dirt-resistant encapsulated stroke system
- Durable sidebands with robust link plate design
- Easy assembly of sidebands
- Long service life due to minimized hinge wear owing to the “life extending 2 disc principle”
- Can be opened on the inside and the outside radius for installation of cables and hoses

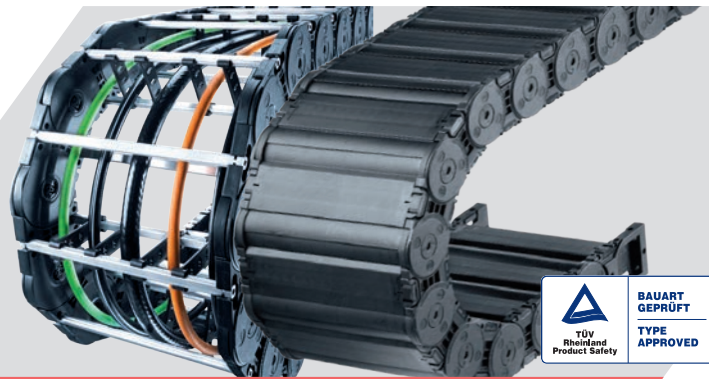

 **B_i increments**
1 mm

TKP91 / TKC91 series

Durable and easy to assemble cable carrier

| | | | |
|---|---|--|--|
|  Inner heights 56 – 80 mm |  Inner widths 150 – 500 mm |  Pitch 91 mm |  Additional load up to 60 kg/m |
|  Travel length unsupported up to 8.9 m |  Travel length gliding up to 100 m |  Travel speed up to 5 m/s |  Acceleration up to 20 m/s ² |

Technical features:

- Many separation options for the cables
- Replacable glide shoe for extended service life in gliding applications
- Extremely robust due to stable plate construction
- Can be opened on inside and outside radius
- Enclosed lids available

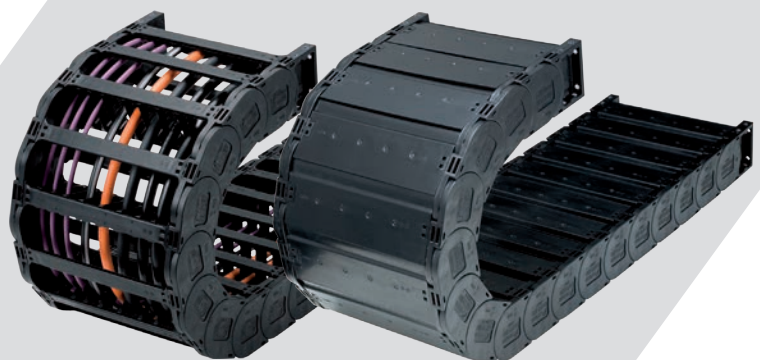

 **B_i increments**
1 mm

XL / XL-Tube series

Cable carrier with large inside height



Inner heights
105 – 108 mm



Inner widths
200 – 1000 mm



Pitch
165 mm



Additional load
up to 65 kg/m



Travel length unsupported
up to 9.5 m



Travel length gliding
up to 350 m



Travel speed
up to 4 m/s



Acceleration
up to 25 m/s²

Technical features:

- For cables with large diameter
- For unsupported and gliding applications
- Replacable glide shoe for extended service life in gliding application
- Aluminium enclosed lids available
- Low intrinsic weight



B₁ increments
1 mm

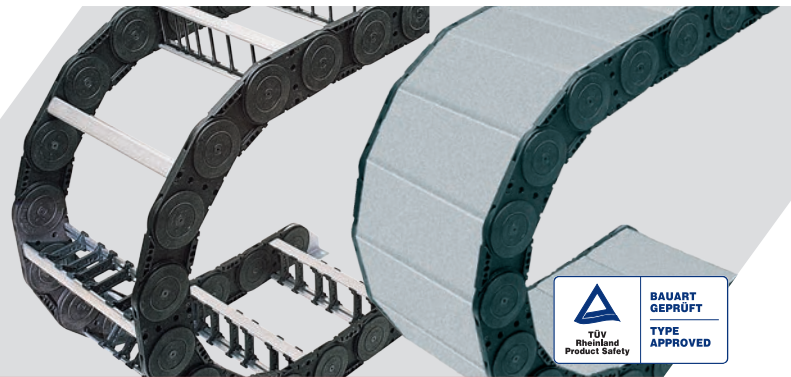

QUANTUM series

Light, quiet, low-vibration for high speeds and accelerations



Inner heights
28 – 72 mm



Inner widths
28 – 600 mm



Pitch
15 – 30 mm



Additional load
up to 12 kg/m



Travel length unsupported
up to 6.5 m



Travel length gliding
up to 200 m



Travel speed
up to 40 m/s



Acceleration
up to 300 m/s²

Technical features:

- Very long service life: 25 million cycles = unsurpassed service life
- Extremely quiet, 31 db (A)*
- Low level of particulate generation during operation
- Suitable for clean rooms
- Practically no polygon effect
- Ideal for highly dynamic applications

*depending on design



B₁ increments
1 mm

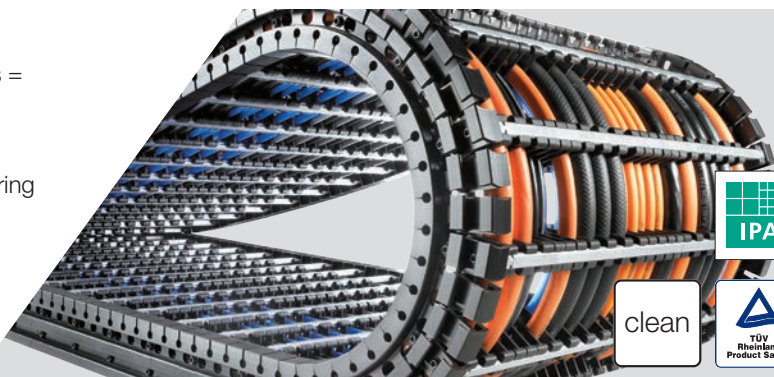

TKR series

Extremely quiet and low-vibration for highly dynamic applications



Inner heights
22 – 52 mm



Inner widths
20 – 200 mm



Pitch
15 – 28 mm



Additional load
up to 10 kg/m



Travel length unsupported
up to 5 m



Travel speed
up to 5 m/s



Acceleration
up to 200 m/s²

Technical features:

- Long service life
- Ideal for highly dynamic applications
- High lateral stability
- Suitable for clean rooms (class 1)
- Extremely quiet and low-vibration
- Practically no polygon effect

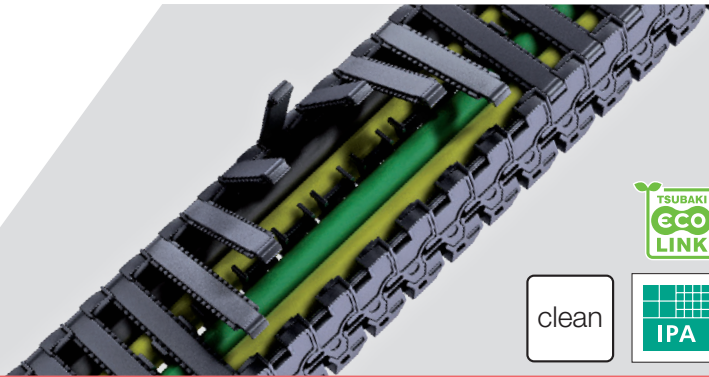

CoverTrax series

For harsh environmental conditions



Inner height
50 mm



Inner widths
50 – 250 mm



Pitch
55.5 mm



Additional load
up to 12 kg/m

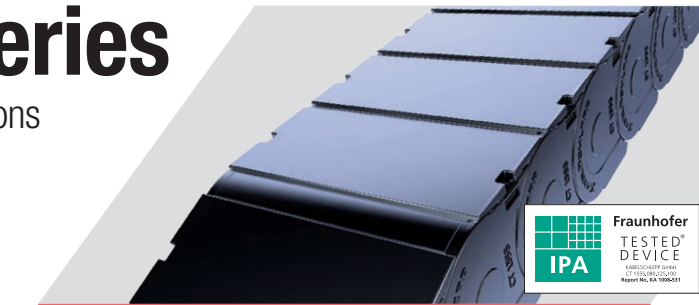

CONDUFLEX series

Enclosed cable carrier



Inner heights
25 – 72 mm



Inner widths
45 – 162 mm



Pitch
20 – 30 mm



Additional load
bis 20 kg/m

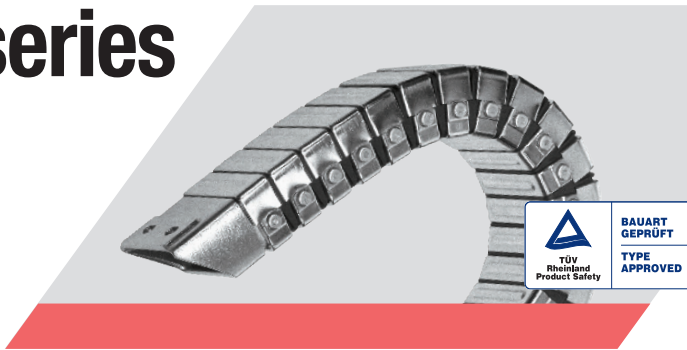

See more:



Steel cable carrier systems

EXTREME APPLICATIONS



Sub-division
complex



Additional load
up to 800 kg/m

Technical features:

- Robust design for heavy mechanical loads
- High additional loads and long self-supporting lengths possible
- Heat-resistant



Inner heights
24 – 578 mm



Travel length unsupported
up to 25 m



Chain widths
26 – 1800 mm



Travel speed
up to 10 m/s



Pitch
105 – 550 mm



Acceleration
up to 20 m/s²

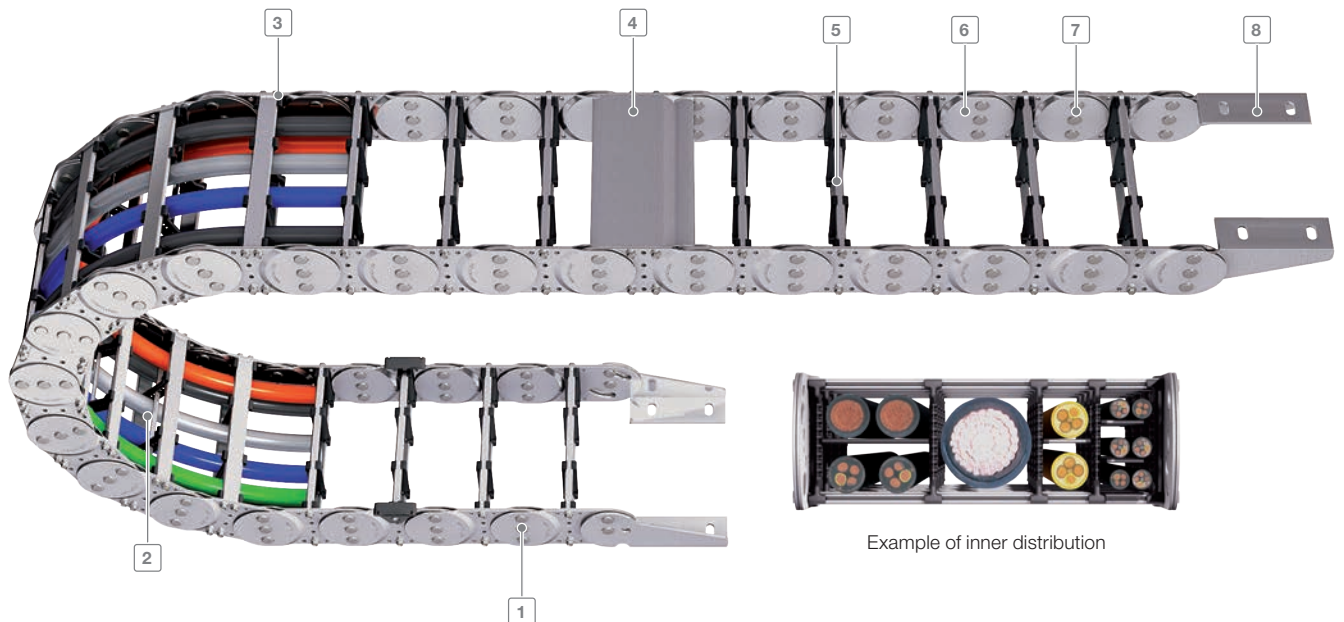

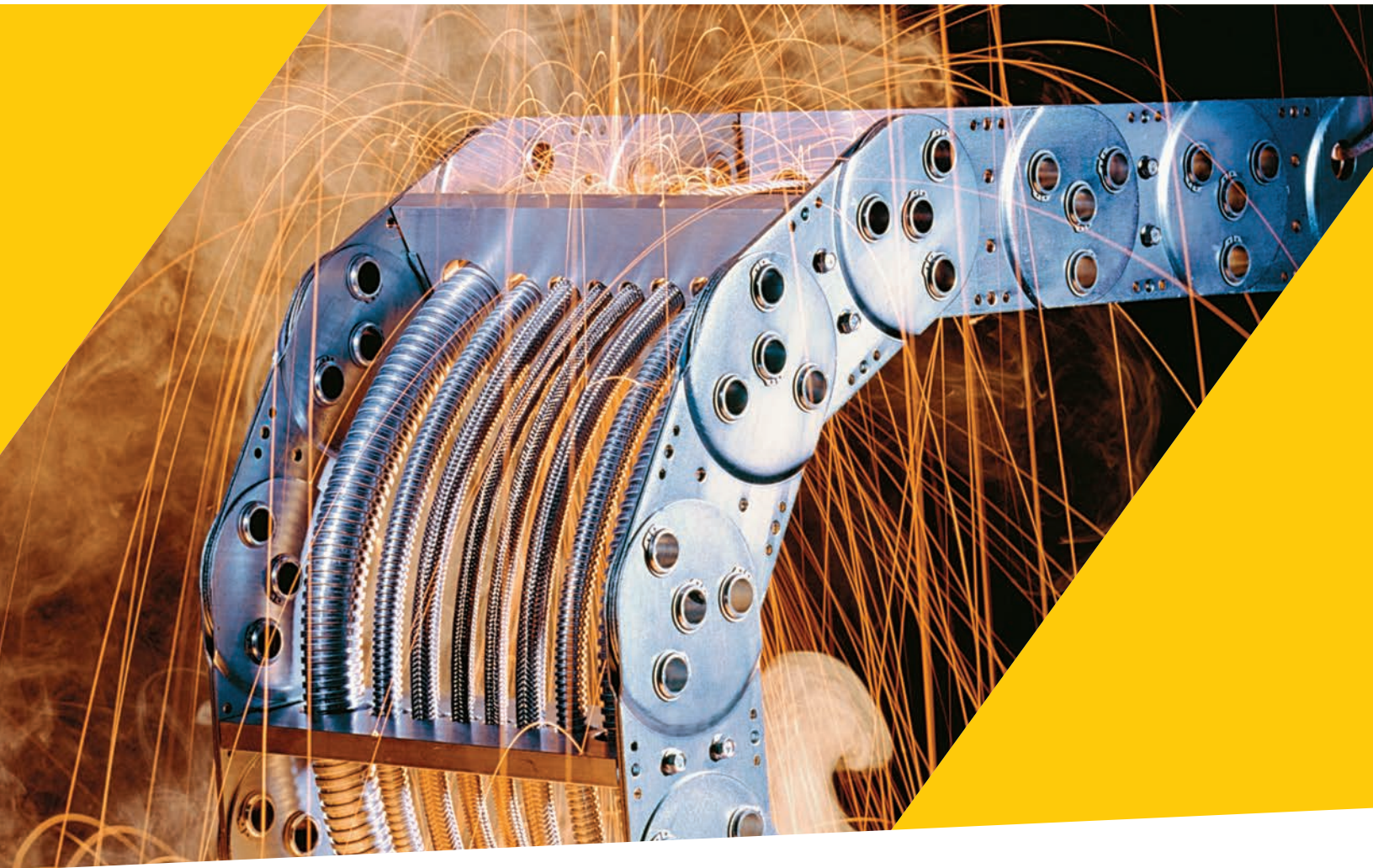

Special applications require the use of special cable carrier systems. Our cable carriers of steel and stainless steel are first choice when it comes to extreme heat or other extremely harsh conditions such as those prevailing in the mining, smelting or oil & gas industry. Customized separation options offer perfect protection for cables and hoses even under high mechanical loads.

- 1 Joint design with hardened bolt for a long service life
- 2 Various cable separation options
- 3 Dividers made of plastic or steel
- 4 Aluminum lids available in 1 mm width sections
- 5 Variety of crossbar options available to allow for complete customization
- 6 Very robust side bands, available galvanized or in stainless steel
- 7 All steel cable carrier are lubrication-free
- 8 End connectors in various connection variants

STEEL
GALVANIZED**STAINLESS
STEEL**
RUST-FREE

WIDTH INCREMENTS



Aluminum stays and covers available in custom widths to the exact millimeter.

LS / LSX series

Cost-effective steel chain in lightweight design



Inner heights
48 – 58 mm



Chain widths
100 – 600 mm



Pitch
105 mm



Additional load
up to 30 kg/m



Travel length unsupported
up to 10 m



Travel speed
up to 5 m/s



Acceleration
up to 10 m/s²

Technical features:

- One-piece link plate constructions
- Sidebands made from hardened steel or stainless steel
- Good corrosion resistance
- Duo band solution available



B₁ increments
1 mm

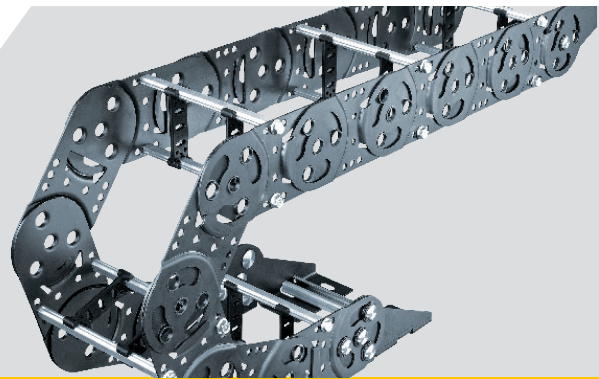

S / SX series & S / SX-Tubes

Extremely robust and strong steel cable carrier



Inner heights
26 – 578 mm



Chain widths
70 – 1800 mm



Pitch
65 – 550 mm



Additional load
up to 800 kg/m



Travel length unsupported
up to 25 m



Travel speed
up to 2.5 m/s



Acceleration
up to 5 m/s²

Technical features:

- Extremely robust, sturdy steel cable carriers for heavy mechanical loads and rough environmental conditions
- Side bands made of steel or stainless steel
- Very sturdy link plates, each consisting of two individual plate
- Very extensive self-supporting lengths
- Explosion protection class EX II 2 GD according to ATEX RL



B₁ increments
1 mm

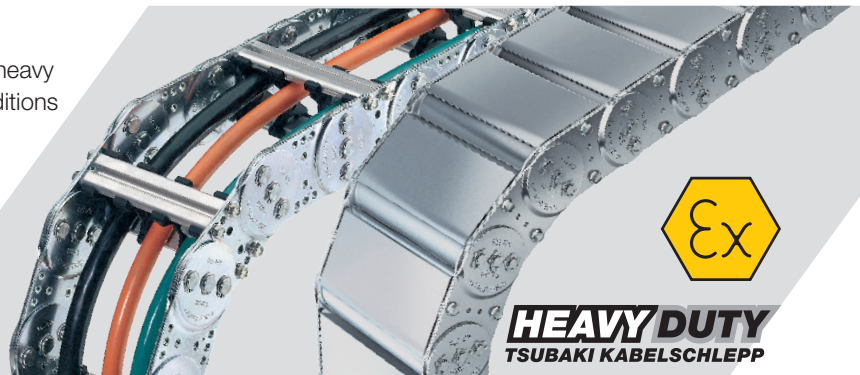

HEAVY DUTY
TSUBAKI KABELSCHLEPP

S / SX 9000 series

Custom cable track designs

TSUBAKI KABELSCHLEPP develops and manufactures steel cable carrier for a variety of applications from steelworks to offshore drilling platforms. We meet the required quality and industry standards and produce

special size cable carrier in different materials to customer specification.

 **Chain widths**
from 350 mm

Technical features:

- Customized solutions
- Maintenance-free systems
- Designed to the application
- Resistant against temperature, corrosion, chemicals and UV light
- Additional load of more than 1000 kg/m
- Explosion protection class EX II 2 GD according to ATEX RL

 **B_i increments**
1 mm

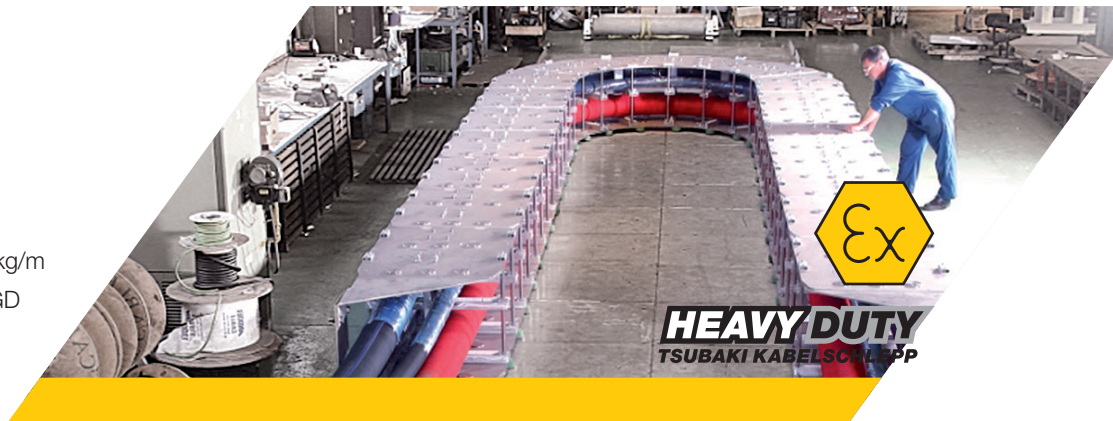

MOBIFLEX series

Enclosed cable carrier with flexible metal helical tube

 **Inner heights**
24 – 167 mm

 **Inner widths**
26 – 170 mm

 **Additional load**
up to 8 kg/m

 **Travel length unsupported**
up to 5 m

 **Travel speed**
up to 10 m/s

 **Acceleration**
up to 20 m/s²

Technical features:

- Tightly sealed design
- Ideal for operating in hot chip environment
- Optimum protection for cables and hoses



Cable and hose carrier systems for 3D movements

3D APPLICATIONS



Sizes
Ø 40 – 100 mm



Sub-division
several

Technical features:

- Perfect for maximum free moving space in 3D applications
- Swiveling and rotational movements on robots in three dimensions, e.g.
 - Areas of robot application from the floor to the robot head
- With channel system, it is a universal solution for rotary applications
- Extension of life for cables in 3D applications
 - through defined minimum bend radius
 - through separating and guiding the cables
- Particularly suitable for high pull forces and fast acceleration

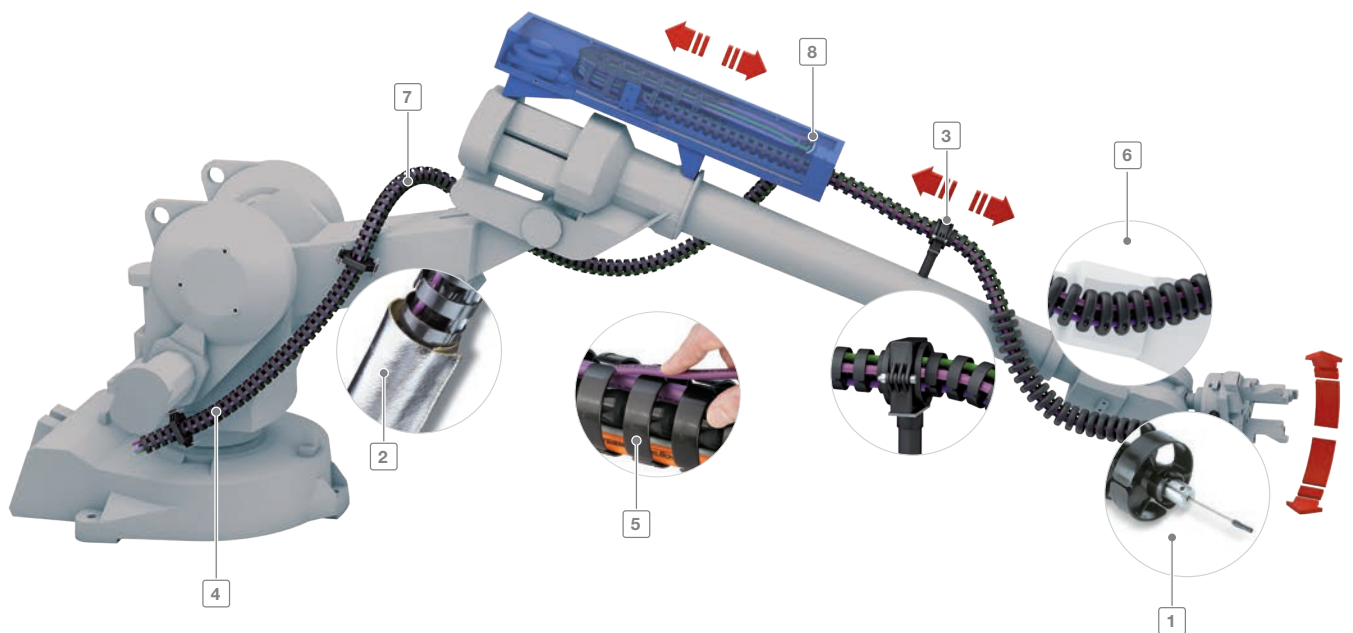



Multidimensional rotating and swiveling movements require a cable carrier that reliably follows all movements while securely leading and protecting all cables and hoses. ROBOTRAX combines these special properties and therefore is especially suitable for applications in robotics and automation. The open design of this product allows quick cable installation and easy inspection of cables and hoses for damage once installed. Additional accessories are available for further optimizing the cable carrier to customer requirement.

- 1 Integrated steel wire for transmission of extremely high pull forces and accelerations
- 2 Protective cover or heat shield made of different materials available for different environmental conditions
- 3 Quick opening bracket reduces installation time
- 4 Simple inspection of cables in the field of vision
- 5 Special nylon for long service life
- 6 Bumper guard protects the cable carrier and inserted cables
- 7 Defined minimum bend radius
- 8 Active pull back mechanism PBU (PULL-BACK UNIT)

ROBOTRAX

Chain links

The basic structure of ROBOTRAX consists of nylon links. These have ball and socket style snap-together connectors on both sides. The individual links can thus be snapped together to form a cable carrier. Internal bend radius stoppers ensure that the minimum bend radius is maintained in all directions. Radial link rotation movement is also possible.

Technical features:

- For three-dimensional movements
- Special nylon for long service life
- Fast cable installation by simple pressing in of the cables – no threading through is necessary
- The cables are cleanly isolated in three separate chambers

 **Inner heights**
10 – 31 mm

 **Inner widths**
27 – 64 mm

 **Pitch**
21.5 – 40 mm

 **Sizes**
Ø 40 – 100 mm



LineFix

Saddle-type clamps for strain relief

Safety grip and gentle cable fixing. Multilayer cable fixing with 2- and 3-fold clamps is possible. Multiple systems can be mounted one behind the other.

 **Suitable for sizes**
Ø 40 – 100 mm

Technical features:

- Continuous strain relief
- Extra stable design
- Solid fit due to innovative foot construction

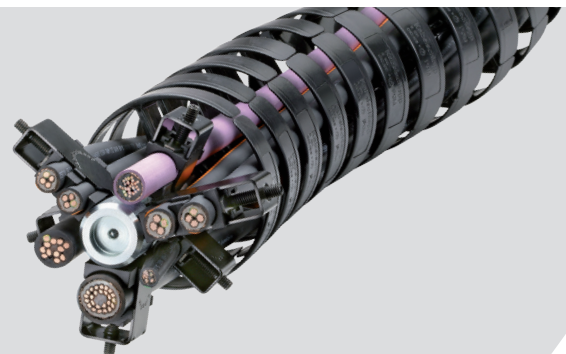

BUMPER GUARD

Impact protection

The Bumper Guard prevents the cable carrier during fast movements and in large work spaces from hard impacts, excessive abrasion and premature wear. Downtime is minimized, since in case of damage only the Bumper Guard needs to be replaced and not the whole cable carrier.



Suitable for sizes
Ø 40 – 100 mm

Technical features:

- Extended life time of the cable carrier
- Protection of robot and cable carrier (impact protection)
- Limited bend radius for cable protection
- Reduced down time due to easy exchange



CHUCKING DEVICE

Provides quick and easy set of the steel wire to the required tension that can be readjusted at any time.



Suitable for sizes
Ø 40 – 100 mm

Technical features:

- Movement of the cable carrier can be adjusted through tension of the steel wire
- Adjustable at any time

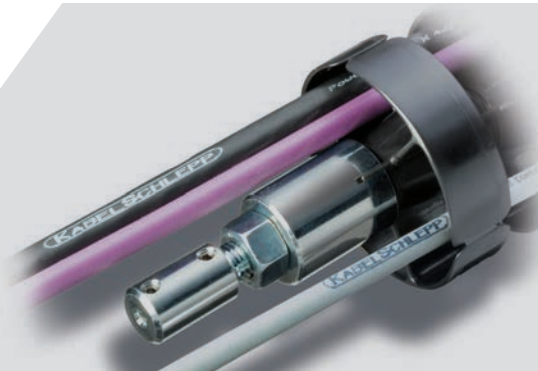

Active pull back mechanism

Pull-Back-Unit (PBU)

The active pull-back mechanismus PULL-BACK UNIT additionally ensures extended service life and reduced downtime. This device keeps the carrier at tension and prevents ROBOTRAX from snagging on the robot, thus protecting the installed cables.



Suitable for sizes
Ø 40 – 100 mm

Technical features:

- Innovative pull-back mechanism without spring
- Compact design
- Robust metal construction
- Housing can be opened for easy access

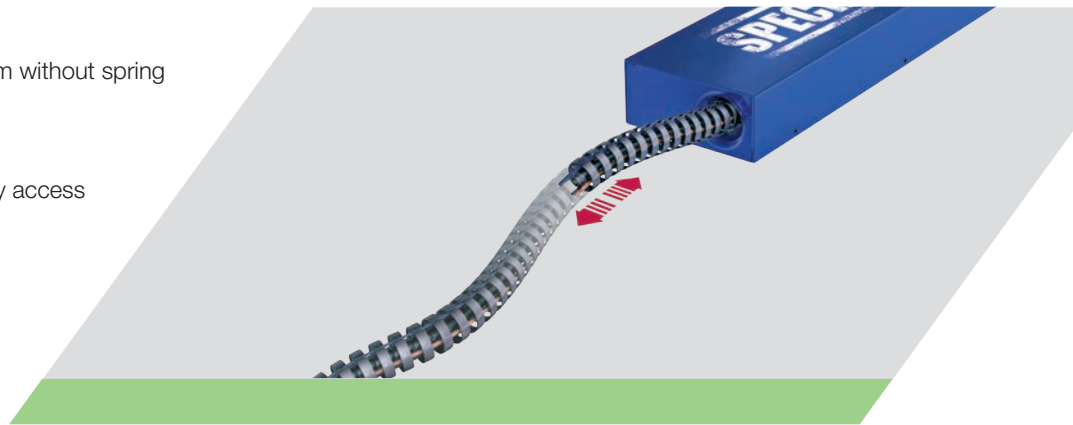

Quick-opening bracket

ROBOTRAX® is fixed and guided with quick-opening brackets that are fixed with two screws. The quick-opening brackets grab the whole single chain link and thus the fixation points can be selected individually.



Suitable for sizes
Ø 40 – 100 mm

Technical features:

- Easy to fix on the robot
- Tool-less installation of the carrier by insertion
- Swivelling version available
- Also available as guide support



Flexible Brackets

If the bracket is mounted on a helical spring, it can move elastically in all directions and support the cable carrier while moving.



Suitable for sizes
Ø 40 – 100 mm

Technical features:

- Can be displaced in 3 dimensions
- Guiding of excess lengths by tracking
- Simple to attach to robot through foot construction

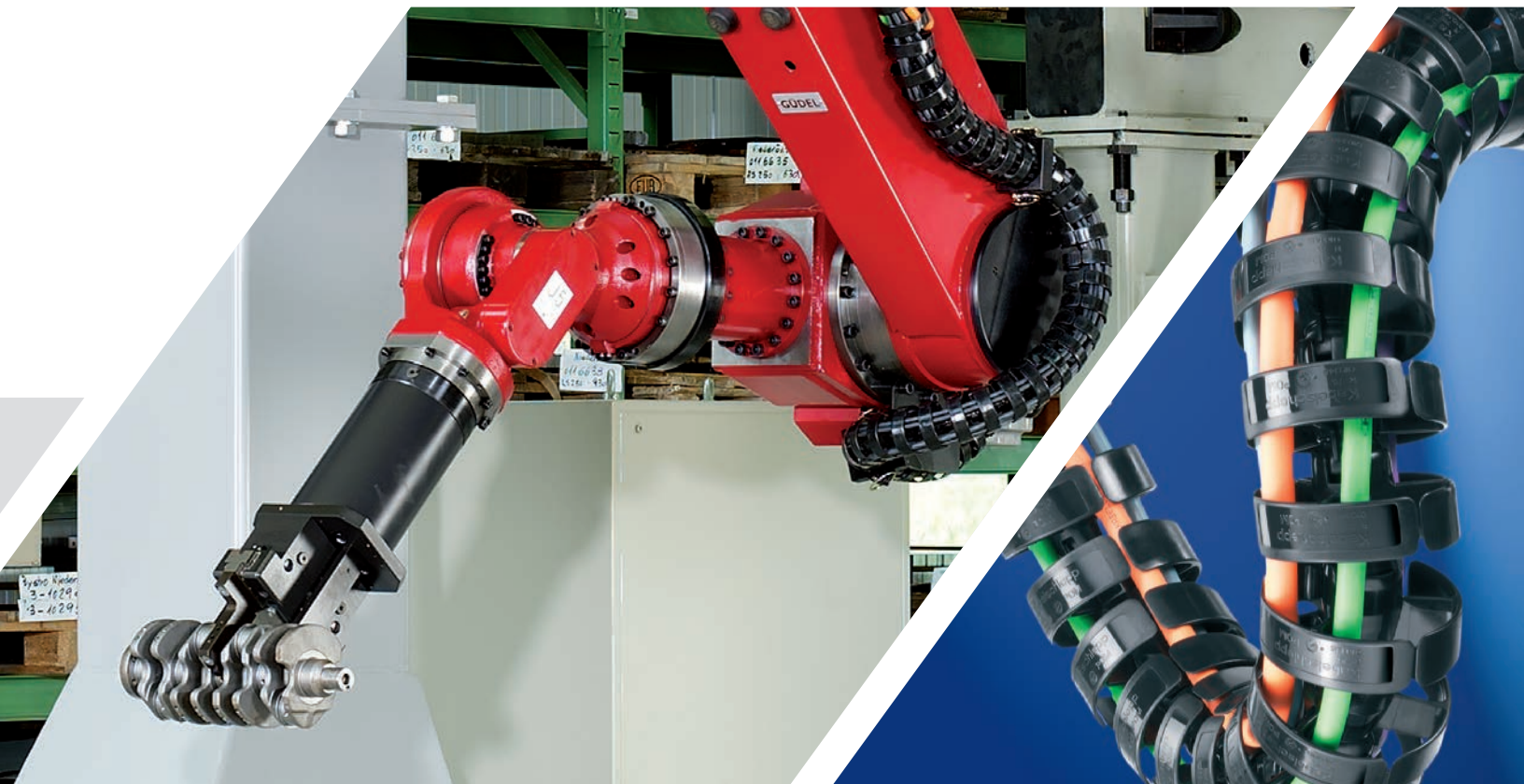
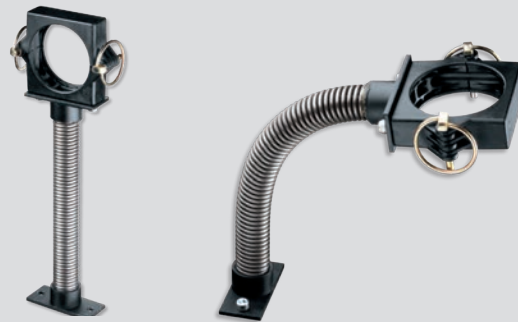

NO CABLE CARRIER WITHOUT A **TRAXLINE®** CABLE

TRAXLINE® Product Portfolio

The TRAXLINE® program is continuously extended and optimized to meet the increasing requirement of cable carrier applications. A unique combination of cable features is available in a clearly structured range of types.

- Highest quality standards
- Cost-efficient, flexible, very durable
- Correspond with all current norms and regulations
- 2D applications (self-supported and gliding)
- 3D applications (cable carrier for robots, rotating)
- For any condition from cleanroom applications to adverse environment

Service & Support:

- Competent, goal-oriented system consultation and worldwide on-site service
- Fast delivery with over 500 types of cables in-stock
- No minimum order amount
- No cutting costs

TRAXLINE® Center

Configure the cables for your cable carrier and find all technical data of our TRAXLINE® cables in the TRAXLINE® Info Center.





Data cable

- Data exchange between moving consumer and stationary end (control cabinet)
- Different quality classes available
- Jacket material: PUR, TPE shield respectively double shield optional
- Used in carriers with small bend radius



BUS-/FOC-/KOAX-cable

- Data exchange between moving consumer and stationary end (control cabinet)
- Different quality classes available
- Jacket material: PUR, TPE shield respectively double shield optional
- Used in carriers with small bend radius



Control cable CONTROL 200, 400, 700, 1000

- Connection for controlling between moving consumer and control cabinet
- Four different quality classes available
- Jacket material: PVC, PUR, TPE; shield optional
- 2 to 49 wires



Motor cable POWER 400, 700, 1000, 4 to 7 wires

- Connection for power supply between moving consumer and control cabinet
- In three different quality classes available
- Jacket material: PVC, PUR, TPE; shield optional
- Cross section from 1,5 mm² to 150 mm²



Motor cable POWER ONE 700, 1000, 1 wire

- For applications in harsh conditions
- Secure transmission of large amounts of energy
- For long travel applications
- Cross section from 0,25 mm² to 700 mm²



Medium voltage cable Heavy Duty, 1 wire

- For applications in harsh conditions
- Secure transmission of large amounts of energy
- For long travel applications
- Cross section from 0,25 mm² to 700 mm²

Competence in systems

TOTALTRAX® COMPLETE SYSTEMS

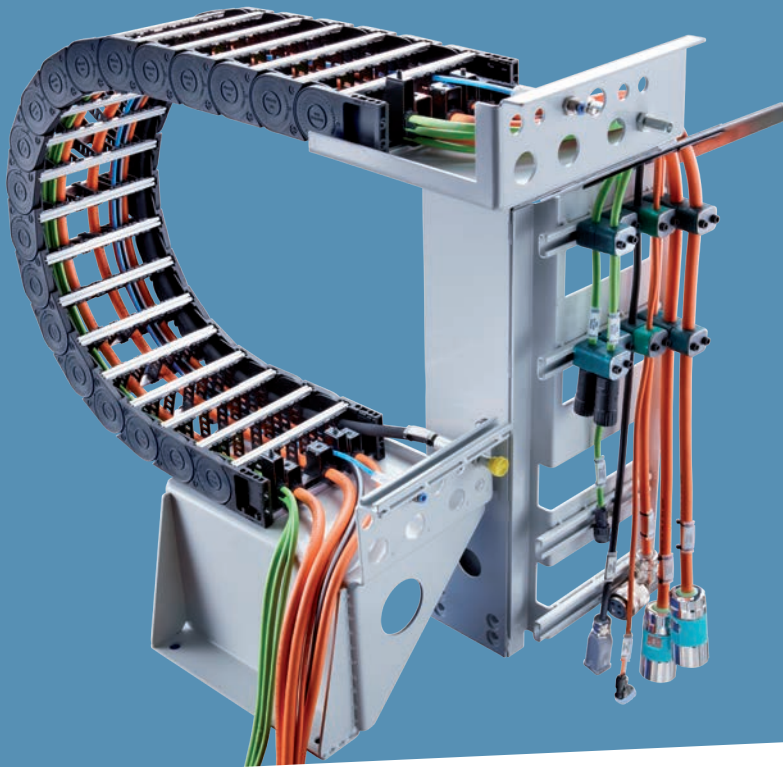

TOTALTRAX®: These are customized complete systems for individual demands and almost all fields of application. Benefit from our experience of thousands of implemented systems, because we do not only provide components but also ready-to-use plug & play solutions. Our product range covers from cable carriers with cables already inserted – so called harnessed cable carrier - up to complex systems. These are jointly developed between our specialists and your experts in a close development cooperation and system partnership. All components used are perfectly matched, thus ensuring high quality and durability. Additional services such as competent advice from our experts during concept phase and professional project support as well as an aftersales service complete the comprehensive range of **TOTALTRAX®** Services.

Further advantages you benefit from:

- Complete delivery from a single source
- Only one contact for the entire system incl. all components
- Reduction of purchasing costs by focusing on just one supplier
- Reduces effort for incoming goods inspection
- Quick installation through ready-to-install modules
- Just-in-Time delivery directly into your production
- Reduced storage costs
- Delivery on special installation and transport racks on request
- System warranty

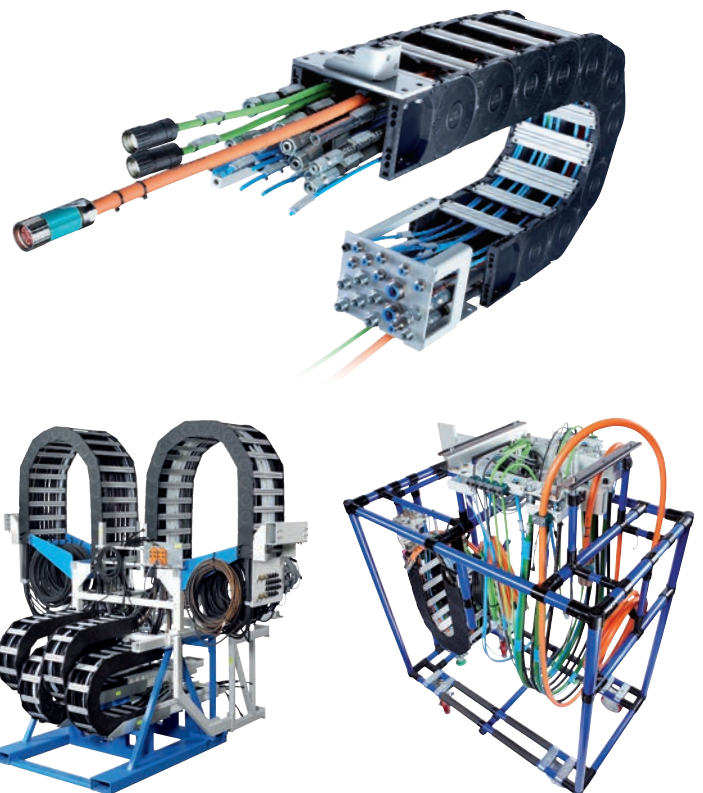

EFFICIENT DESIGN ACCURATE AND FAST



Shorten your design time, accelerate your design processes, do concept development with original data from the manufacturer. We continuously invest in the online supply of product-related information to make your work easier. Thereby you can access the latest product and CAD data during the design phase. Currently, we provide comprehensive, technical information in three different, partly interlinked online tools.



Our web-based platform OnlineEngineer that is available throughout the world supports you with multiple functions for

selecting and configuring the right product for your application. Here, all relevant technical and commercial information about all individual products from the ranges of cable carriers, cables and accessories is centrally pooled and clearly displayed. By entering different parameters it facilitates to select the appropriate products.

For even more convenience the data portals OnlineEngineer and CADENAS is interlinked. This allows you to easily download the respective CAD model without leaving the OnlineEngineer once you have completed your product configuration. Vice versa, data from OnlineEngineer can be retrieved while working in CADENAS.

CADENAS 3D CAD CATALOGUE

CADENAS is an international platform for providing 3D models in various CAD formats. Numerous renowned companies from machinery and plant engineering as well as from other industries are represented. Currently, we provide CAD models for our entire product portfolio in all common CAD formats. Moreover, the database contains the corresponding models for guide channels and support trays. We continuously update the scope offered.

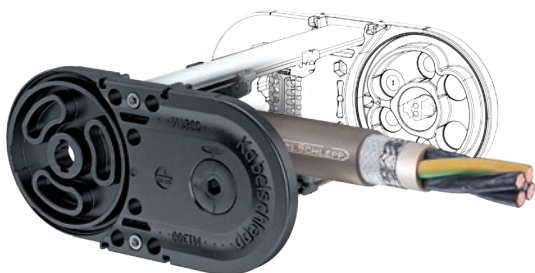

Electrical Engineering with ePLAN

EPLAN Data Portal is an integrated, web-based data platform delivering the most recent device data from market-leading component manufacturers for direct use in the EPLAN planning software. For those using the global project planning software EPLAN Electric P8, we offer technical and commercial information of our TRAXLINE® cables in the EPLAN Data Portal for download.



KABELSCHLEPP

CABLE CARRIER SYSTEMS

Cable Carrier Systems
Cable carriers made of steel and plastic
QUANTUM cable and hose carrier system
PROTUM cable and hose carrier system
ROBOTRAX cable and hose carrier system

TRAXLINE® – CABLES FOR MOTION

Continuous bending hi-flex cables for cable carriers
TOTALTRAX® complete turn-key carrier systems
Pre-assembled cables

GUIDEWAY PROTECTION SYSTEMS

Telescopic covers
Link apron covers
Way wipers
Conical spring covers
Bellows
Protective devices

CONVEYOR SYSTEMS

Hinged belt conveyors
Scraper conveyors
Belt conveyors



Corporate Headquarters
U.S. Tsubaki Power Transmission, LLC
301 E. Marquardt Drive
Wheeling, IL 60090
Tel: (800) 323-7790
Fax: (947) 459-9515
www.ustsubaki.com



Roller Chain Division
821 Main Street
Holyoke, MA 01040
Tel: (800) 323-7790



Conveyor & Construction
Chain Division
1010 Edgewater Drive
Sandusky, OH 44870
Tel: (800) 537-6140
Fax: (419) 626-5194



Sprocket Manufacturing
Mississauga, Ontario
Tel: (800) 323-7790



Cable & Hose Carrier Division
7100 W. Marcia Road
Milwaukee, WI 53223
Tel: (800) 443-4216
Fax: (414) 354-1900